

# **NATIONAL ELIGIBILITY CUM ENTRANCE TEST NEET (UG), 2017 BOOKLET CODE-A (APRA)**

Time : 3 hrs.

## **Answers & Solutions**

Max. Marks : 720

### **Important Instructions :**

1. The Answer Sheet is inside this Test Booklet. When you are directed to open the Test Booklet, take out the Answer Sheet and fill in the particulars on **Side-1** and **Side-2** carefully with **blue / black** ball point pen only.
2. The test is of **3 hours** duration and Test Booklet contains **180** questions. Each question carries **4** marks. For each correct response, the candidate will get **4 marks**. For each incorrect response, **one mark** will be deducted from the total scores. The maximum marks are **720**.
3. Use **Blue / Black Ball Point Pen only** for writing particulars on this page / marking responses.
4. Rough work is to be done on the space provided for this purpose in the Test Booklet only.
5. **On completion of the test, the candidate must hand over the Answer Sheet to the invigilator before leaving the Room / Hall. The candidates are allowed to take away this Test Booklet with them.**
6. The CODE for this Booklet is **A**. Make sure that the CODE printed on **Side-2** of the Answer Sheet is the same as that on this Booklet. In case of discrepancy, the candidate should immediately report the matter to the Invigilator for replacement of both the Test Booklet and the Answer Sheet.
7. The candidates should ensure that the Answer Sheet is not folded. Do not make any stray marks on the Answer Sheet. Do not write your Roll No. anywhere else except in the specified space in the Test Booklet / Answer Sheet.
8. Use of white fluid for correction is **NOT** permissible on the Answer Sheet.
9. Each candidate must show on demand his / her Admit Card to the Invigilator.
10. No candidate, without special permission of the Superintendent or Invigilator, would leave his / her seat.
11. The candidates should not leave the Examination Hall without handing over their Answer Sheet to the Invigilator on duty and sign the Attendance Sheet twice. **Cases where a candidate has not signed the Attendance Sheet second time will be deemed not to have handed over the Answer Sheet and dealt with as an unfair means case.**
12. Use of Electronic / Manual Calculator is prohibited.
13. The candidates are governed by all Rules and Regulations of the examination with regard to their conduct in the Examination Hall. All cases of unfair means will be dealt with as per Rules and Regulations of this examination.
14. No part of the Test Booklet and Answer Sheet shall be detached under any circumstances.
15. The candidates will write the Correct Test Booklet Code as given in the Test Booklet / Answer Sheet in the Attendance Sheet.

1. A potentiometer is an accurate and versatile device to make electrical measurements of E.M.F, because the method involves :

- (1) Cells
- (2) Potential gradients
- (3) A condition of no current flow through the galvanometer
- (4) A combination of cells, galvanometer and resistances

**Answer (3)**

**Sol.** Reading of potentiometer is accurate because during taking reading it does not draw any current from the circuit.

2. A gas mixture consists of 2 moles of O<sub>2</sub> and 4 moles of Ar at temperature *T*. Neglecting all vibrational modes, the total internal energy of the system is

- (1) 4 *RT*
- (2) 15 *RT*
- (3) 9 *RT*
- (4) 11 *RT*

**Answer (4)**

**Sol.**  $U = n_1 \frac{f_1}{2} RT + n_2 \frac{f_2}{2} RT$   
 $= 2 \times \frac{5}{2} RT + 4 \times \frac{3}{2} RT$   
 $= 5 RT + 6 RT$   
 $U = 11 RT$

3. Radioactive material 'A' has decay constant '8λ' and material 'B' has decay constant 'λ'. Initially they have same number of nuclei. After what time, the ratio of number of nuclei of material 'B' to that 'A' will be  $\frac{1}{e}$ ?

- (1)  $\frac{1}{\lambda}$
- (2)  $\frac{1}{7\lambda}$
- (3)  $\frac{1}{8\lambda}$
- (4)  $\frac{1}{9\lambda}$

**Answer (2)**

**Sol.** No option is correct

If we take  $\frac{N_A}{N_B} = \frac{1}{e}$

Then

$$\frac{N_A}{N_B} = \frac{e^{-8\lambda t}}{e^{-\lambda t}}$$

$$\frac{1}{e} = e^{-7\lambda t}$$

$$-1 = -7\lambda t$$

$$t = \frac{1}{7\lambda}$$

4. A U tube with both ends open to the atmosphere, is partially filled with water. Oil, which is immiscible with water, is poured into one side until it stands at a distance of 10 mm above the water level on the other side. Meanwhile the water rises by 65 mm from its original level (see diagram). The density of the oil is

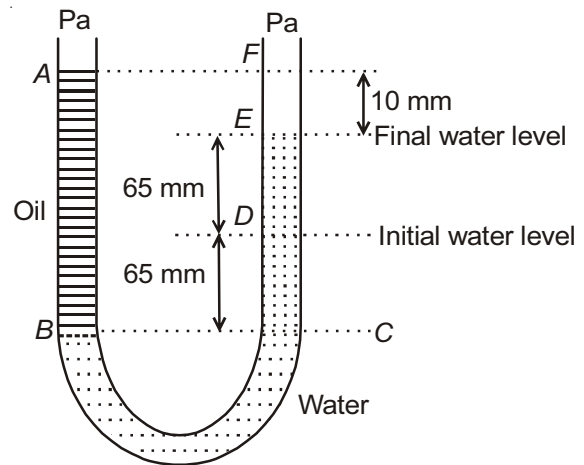

- (1) 650 kg m<sup>-3</sup>
- (2) 425 kg m<sup>-3</sup>
- (3) 800 kg m<sup>-3</sup>
- (4) 928 kg m<sup>-3</sup>

**Answer (4)**

**Sol.**  $h_{oil} \rho_{oil} g = h_{water} \rho_{water} g$

$$140 \times \rho_{oil} = 130 \times \rho_{water}$$

$$\rho_{oil} = \frac{13}{14} \times 1000 \text{ kg/m}^3$$

$$\rho_{oil} = 928 \text{ kg m}^{-3}$$

5. A 250-Turn rectangular coil of length 2.1 cm and width 1.25 cm carries a current of 85 μA and subjected to a magnetic field of strength 0.85 T. Work done for rotating the coil by 180° against the torque is

- (1) 9.1 μJ
- (2) 4.55 μJ
- (3) 2.3 μJ
- (4) 1.15 μJ

**Answer (1)**

**Sol.**  $W = MB (\cos\theta_1 - \cos\theta_2)$

When it is rotated by angle  $180^\circ$  then

$$W = 2MB$$

$$W = 2(NIA)B$$

$$= 2 \times 250 \times 85 \times 10^{-6} [1.25 \times 2.1 \times 10^{-4}] \times 85$$

$$\times 10^{-2}$$

$$= 9.1 \mu\text{J}$$

6. The de-Broglie wavelength of a neutron in thermal equilibrium with heavy water at a temperature  $T$  (Kelvin) and mass  $m$ , is

(1)  $\frac{h}{\sqrt{mkT}}$                       (2)  $\frac{h}{\sqrt{3mkT}}$

(3)  $\frac{2h}{\sqrt{3mkT}}$                       (4)  $\frac{2h}{\sqrt{mkT}}$

**Answer (2)**

**Sol.** de-Broglie wavelength

$$\lambda = \frac{h}{mv}$$

$$= \frac{h}{\sqrt{2m(\text{KE})}}$$

$$= \frac{h}{\sqrt{2m\left(\frac{3}{2}kT\right)}}$$

$$\lambda = \frac{h}{\sqrt{3mkT}}$$

7. One end of string of length  $l$  is connected to a particle of mass ' $m$ ' and the other end is connected to a small peg on a smooth horizontal table. If the particle moves in circle with speed ' $v$ ', the net force on the particle (directed towards center) will be ( $T$  represents the tension in the string)

(1)  $T$

(2)  $T + \frac{mv^2}{l}$

(3)  $T - \frac{mv^2}{l}$

(4) Zero

**Answer (1)**

**Sol.** Centripetal force  $\left(\frac{mv^2}{l}\right)$  is provided by tension so

the net force will be equal to tension i.e.,  $T$ .

8. Figure shows a circuit contains three identical resistors with resistance  $R = 9.0 \Omega$  each, two identical inductors with inductance  $L = 2.0 \text{ mH}$  each, and an ideal battery with emf  $\varepsilon = 18 \text{ V}$ . The current ' $i$ ' through the battery just after the switch closed is

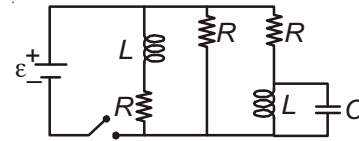

- (1) 2 mA  
 (2) 0.2 A  
 (3) 2 A  
 (4) 0 ampere

**Answer (3\*)**

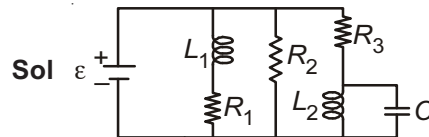

At  $t = 0$ , no current flows through  $R_1$  and  $R_3$

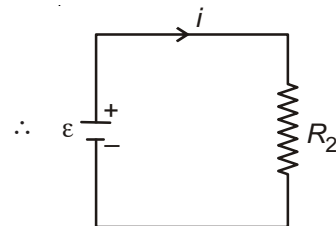

$$i = \frac{\varepsilon}{R_2}$$

$$= \frac{18}{9}$$

$$= 2 \text{ A}$$

**Note :** Not correctly framed but the best option out of given is (3).

9. The  $x$  and  $y$  coordinates of the particle at any time are  $x = 5t - 2t^2$  and  $y = 10t$  respectively, where  $x$  and  $y$  are in meters and  $t$  in seconds. The acceleration of the particle at  $t = 2 \text{ s}$  is

- (1) 0  
 (2)  $5 \text{ m/s}^2$   
 (3)  $-4 \text{ m/s}^2$   
 (4)  $-8 \text{ m/s}^2$

**Answer (3)**

**Sol.**  $x = 5t - 2t^2$                        $y = 10t$

$$\frac{dx}{dt} = 5 - 4t \quad \frac{dy}{dt} = 10$$

$$v_x = 5 - 4t \quad v_y = 10$$

$$\frac{dv}{dt} x = -4 \quad \frac{dv}{dt} y = 10$$

$$a_x = -4 \quad a_y = 0$$

Acceleration of particle at  $t = 2$  s is  $= -4$  m/s<sup>2</sup>

10. Suppose the charge of a proton and an electron differ slightly. One of them is  $-e$ , the other is  $(e + \Delta e)$ . If the net of electrostatic force and gravitational force between two hydrogen atoms placed at a distance  $d$  (much greater than atomic size) apart is zero, then  $\Delta e$  is of the order of [Given mass of hydrogen  $m_h = 1.67 \times 10^{-27}$  kg]

- (1)  $10^{-20}$  C
- (2)  $10^{-23}$  C
- (3)  $10^{-37}$  C
- (4)  $10^{-47}$  C

**Answer (3)**

**Sol.**  $F_e = F_g$

$$\frac{1}{4\pi\epsilon_0} \frac{\Delta e^2}{d^2} = \frac{Gm^2}{d^2}$$

$$9 \times 10^9 (\Delta e^2) = 6.67 \times 10^{-11} \times 1.67 \times 10^{-27} \times 1.67 \times 10^{-27}$$

$$\Delta e^2 = \frac{6.67 \times 1.67 \times 1.67}{9} \times 10^{-74}$$

$$\Delta e \approx 10^{-37}$$

11. Two rods A and B of different materials are welded together as shown in figure. Their thermal conductivities are  $K_1$  and  $K_2$ . The thermal conductivity of the composite rod will be

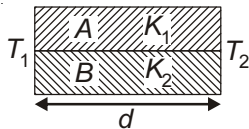

- (1)  $\frac{K_1 + K_2}{2}$
- (2)  $\frac{3(K_1 + K_2)}{2}$
- (3)  $K_1 + K_2$
- (4)  $2(K_1 + K_2)$

**Answer (1)**

**Sol.** Thermal current

$$H = H_1 + H_2$$

$$= \frac{K_1 A (T_1 - T_2)}{d} + \frac{K_2 A (T_1 - T_2)}{d}$$

$$\frac{K_{EQ} 2A (T_1 - T_2)}{d} = \frac{A (T_1 - T_2)}{d} [K_1 + K_2]$$

$$K_{EQ} = \left[ \frac{K_1 + K_2}{2} \right]$$

12. The diagrams below show regions of equipotentials.

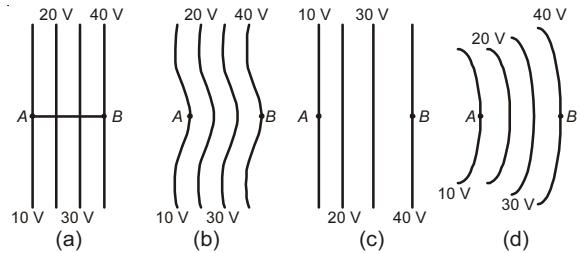

A positive charge is moved from A to B in each diagram.

- (1) Maximum work is required to move  $q$  in figure (c).
- (2) In all the four cases the work done is the same.
- (3) Minimum work is required to move  $q$  in figure (a).
- (4) Maximum work is required to move  $q$  in figure (b).

**Answer (2)**

**Sol.** Work done  $w = q\Delta V$

$\Delta V$  is same in all the cases so work is done will be same in all the cases.

13. The ratio of wavelengths of the last line of Balmer series and the last line of Lyman series is

- (1) 2
- (2) 1
- (3) 4
- (4) 0.5

**Answer (3)**

**Sol.** For last Balmer series

$$\frac{1}{\lambda_b} = R \left[ \frac{1}{2^2} - \frac{1}{\infty^2} \right]$$

$$\lambda_b = \frac{4}{R}$$

For last Lyman series

$$\frac{1}{\lambda_l} = R \left[ \frac{1}{1^2} - \frac{1}{\infty^2} \right]$$

$$\lambda_l = \frac{1}{R}$$

$$\frac{\lambda_b}{\lambda_l} = \frac{4}{R} = \frac{1}{R}$$

$$\frac{\lambda_b}{\lambda_l} = 4$$

14. Young's double slit experiment is first performed in air and then in a medium other than air. It is found that 8<sup>th</sup> bright fringe in the medium lies where 5<sup>th</sup> dark fringe lies in air. The refractive index of the medium is nearly

- (1) 1.25  
 (2) 1.59  
 (3) 1.69  
 (4) 1.78

**Answer (4)**

**Sol.**  $X_1 = X_{5^{\text{th dark}}} = (2 \times 5 - 1) \frac{\lambda D}{2d}$

$$X_2 = X_{8^{\text{th bright}}} = 8 \frac{\lambda D}{\mu d}$$

$$X_1 = X_2$$

$$\frac{9 \lambda D}{2 d} = 8 \frac{\lambda D}{\mu d}$$

$$\mu = \frac{16}{9} = 1.78$$

15. A particle executes linear simple harmonic motion with an amplitude of 3 cm. When the particle is at 2 cm from the mean position, the magnitude of its velocity is equal to that of its acceleration. Then its time period in seconds is

- (1)  $\frac{\sqrt{5}}{\pi}$   
 (2)  $\frac{\sqrt{5}}{2\pi}$   
 (3)  $\frac{4\pi}{\sqrt{5}}$   
 (4)  $\frac{2\pi}{\sqrt{3}}$

**Answer (3)**

**Sol.**  $v = \omega \sqrt{A^2 - x^2}$

$$a = x\omega^2$$

$$v = a$$

$$\omega \sqrt{A^2 - x^2} = x\omega^2$$

$$\sqrt{(3)^2 - (2)^2} = 2 \left( \frac{2\pi}{T} \right)$$

$$\sqrt{5} = \frac{4\pi}{T}$$

$$T = \frac{4\pi}{\sqrt{5}}$$

16. Thermodynamic processes are indicated in the following diagram.

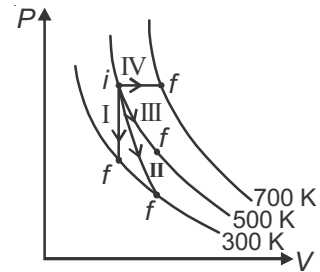

Match the following

Column-1	Column-2
P. Process I	a. Adiabatic
Q. Process II	b. Isobaric
R. Process III	c. Isochoric
S. Process IV	d. Isothermal

- (1) P → a, Q → c, R → d, S → b  
 (2) P → c, Q → a, R → d, S → b  
 (3) P → c, Q → d, R → b, S → a  
 (4) P → d, Q → b, R → a, S → c

**Answer (2)**

**Sol.** Process I = Isochoric

II = Adiabatic

III = Isothermal

IV = Isobaric

17. A capacitor is charged by a battery. The battery is removed and another identical uncharged capacitor is connected in parallel. The total electrostatic energy of resulting system

- (1) Increases by a factor of 4  
 (2) Decreases by a factor of 2  
 (3) Remains the same  
 (4) Increases by a factor of 2

**Answer (2)**

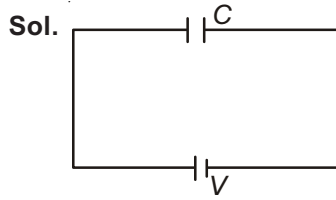

Charge on capacitor

$$q = CV$$

when it is connected with another uncharged capacitor.

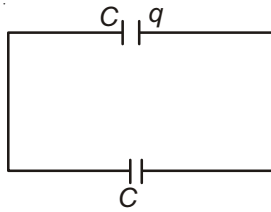

$$V_c = \frac{q_1 + q_2}{C_1 + C_2} = \frac{q + 0}{C + C}$$

$$V_c = \frac{V}{2}$$

Initial energy

$$U_i = \frac{1}{2} CV^2$$

Final energy

$$U_f = \frac{1}{2} C \left( \frac{V}{2} \right)^2 + \frac{1}{2} C \left( \frac{V}{2} \right)^2$$

$$= \frac{CV^2}{4}$$

Loss of energy =  $U_i - U_f$

$$= \frac{CV^2}{4}$$

i.e. decreases by a factor (2)

18. The photoelectric threshold wavelength of silver is  $3250 \times 10^{-10}$  m. The velocity of the electron ejected from a silver surface by ultraviolet light of wavelength  $2536 \times 10^{-10}$  m is

(Given  $h = 4.14 \times 10^{-15}$  eVs and  $c = 3 \times 10^8$  ms<sup>-1</sup>)

- (1)  $\approx 6 \times 10^5$  ms<sup>-1</sup>  
 (2)  $\approx 0.6 \times 10^6$  ms<sup>-1</sup>  
 (3)  $\approx 61 \times 10^3$  ms<sup>-1</sup>  
 (4)  $\approx 0.3 \times 10^6$  ms<sup>-1</sup>

**Answer (1 & 2)\* Both answers are correct.**

Sol.  $\lambda_0 = 3250 \times 10^{-10}$  m

$$\lambda = 2536 \times 10^{-10}$$
 m

$$\phi = \frac{1242 \text{ eV-nm}}{325 \text{ nm}} = 3.82 \text{ eV}$$

$$h\nu = \frac{1242 \text{ eV-nm}}{253.6 \text{ nm}} = 4.89 \text{ eV}$$

$$KE_{\text{max}} = (4.89 - 3.82) \text{ eV} = 1.077 \text{ eV}$$

$$\frac{1}{2} m v^2 = 1.077 \times 1.6 \times 10^{-19}$$

$$v = \sqrt{\frac{2 \times 1.077 \times 1.6 \times 10^{-19}}{9.1 \times 10^{-31}}}$$

$$v = 0.6 \times 10^6 \text{ m/s}$$

19. A physical quantity of the dimensions of length that

can be formed out of  $c$ ,  $G$  and  $\frac{e^2}{4\pi\epsilon_0}$  is [ $c$  is velocity

of light,  $G$  is universal constant of gravitation and  $e$  is charge]

(1)  $\frac{1}{c^2} \left[ G \frac{e^2}{4\pi\epsilon_0} \right]^{\frac{1}{2}}$

(2)  $c^2 \left[ G \frac{e^2}{4\pi\epsilon_0} \right]^{\frac{1}{2}}$

(3)  $\frac{1}{c^2} \left[ \frac{e^2}{G4\pi\epsilon_0} \right]^{\frac{1}{2}}$

(4)  $\frac{1}{c} G \frac{e^2}{4\pi\epsilon_0}$

**Answer (1)**

Sol. Let  $\frac{e^2}{4\pi\epsilon_0} = A = ML^3T^{-2}$

$$l = C^x G^y (A)^z$$

$$L = [LT^{-1}]^x [M^{-1}L^3T^{-2}]^y [ML^3T^{-2}]^z$$

$$-y + z = 0 \Rightarrow y = z \quad \dots(i)$$

$$x + 3y + 3z = 1 \quad \dots(ii)$$

$$-x - 4z = 0 \quad \dots(iii)$$

From (i), (ii) & (iii)

$$z = y = \frac{1}{2}, \quad x = -2$$

20. Two cars moving in opposite directions approach each other with speed of 22 m/s and 16.5 m/s respectively. The driver of the first car blows a horn having a frequency 400 Hz. The frequency heard by the driver of the second car is [velocity of sound 340 m/s]

- (1) 350 Hz                      (2) 361 Hz  
 (3) 411 Hz                      (4) 448 Hz

**Answer (4)**

**Sol.**  $f_A = f \left[ \frac{v + v_o}{v - v_s} \right]$   
 $= 400 \left[ \frac{340 + 16.5}{340 - 22} \right]$

$f_A = 448 \text{ Hz}$

21. In a common emitter transistor amplifier the audio signal voltage across the collector is 3 V. The resistance of collector is 3 kΩ. If current gain is 100 and the base resistance is 2 kΩ, the voltage and power gain of the amplifier is

- (1) 200 and 1000  
 (2) 15 and 200  
 (3) 150 and 15000  
 (4) 20 and 2000

**Answer (3)**

**Sol.** Current gain ( $\beta$ ) = 100

Voltage gain ( $A_v$ ) =  $\beta \frac{R_c}{R_b}$   
 $= 100 \left( \frac{3}{2} \right)$   
 $= 150$

Power gain =  $A_v \beta$   
 $= 150 (100)$   
 $= 15000$

22. Which one of the following represents forward bias diode?

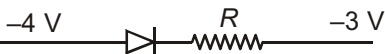
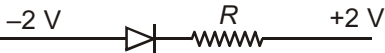
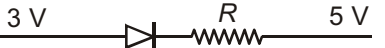
- (1)   
 (2)   
 (3)   
 (4) 

**Answer (1)**

**Sol.** In forward bias, p-type semiconductor is at higher potential w.r.t. n-type semiconductor.

23. A spring of force constant  $k$  is cut into lengths of ratio 1 : 2 : 3. They are connected in series and the new force constant is  $k'$ . Then they are connected in parallel and force constant is  $k''$ . Then  $k' : k''$  is

- (1) 1 : 6                      (2) 1 : 9  
 (3) 1 : 11                      (4) 1 : 14

**Answer (3)**

**Sol.** Spring constant  $\propto \frac{1}{\text{length}}$

$k \propto \frac{1}{l}$

i.e,  $k_1 = 6k$

$k_2 = 3k$

$k_3 = 2k$

In series

$\frac{1}{k'} = \frac{1}{6k} + \frac{1}{3k} + \frac{1}{2k}$

$\frac{1}{k'} = \frac{6}{6k}$

$k' = k$

$k'' = 6k + 3k + 2k$

$k'' = 11k$

$\frac{k'}{k''} = \frac{1}{11}$  i.e  $k' : k'' = 1 : 11$

24. The given electrical network is equivalent to

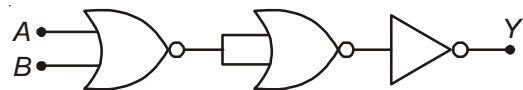

- (1) AND gate  
 (2) OR gate  
 (3) NOR gate  
 (4) NOT gate

**Answer (3)**

**Sol.**  $Y = \overline{A + B}$

25. The acceleration due to gravity at a height 1 km above the earth is the same as at a depth  $d$  below the surface of earth. Then

- (1)  $d = \frac{1}{2}$  km                      (2)  $d = 1$  km  
 (3)  $d = \frac{3}{2}$  km                      (4)  $d = 2$  km

**Answer (4)**

**Sol.** Above earth surface

$$g' = g \left( 1 - \frac{2h}{R_e} \right)$$

$$\Delta g' = g \frac{2h}{R_e} \dots(1)$$

From (1) & (2)

$$d = 2h$$

$$d = 2 \times 1 \text{ km}$$

Below earth surface

$$g' = g \left( 1 - \frac{d}{R_e} \right)$$

$$\Delta g = g \frac{d}{R_e} \dots(2)$$

26. Which of the following statements are correct?

- (a) Centre of mass of a body always coincides with the centre of gravity of the body.  
 (b) Centre of mass of a body is the point at which the total gravitational torque on the body is zero  
 (c) A couple on a body produce both translational and rotational motion in a body.  
 (d) Mechanical advantage greater than one means that small effort can be used to lift a large load.

- (1) (b) and (d)                      (2) (a) and (b)  
 (3) (b) and (c)                      (4) (c) and (d)

**Answer (1)**

**Sol.** Centre of mass may or may not coincide with centre of gravity.

27. A Carnot engine having an efficiency of  $\frac{1}{10}$  as heat engine, is used as a refrigerator. If the work done on the system is 10 J, the amount of energy absorbed from the reservoir at lower temperature is

- (1) 1 J                                      (2) 90 J  
 (3) 99 J                                      (4) 100 J

**Answer (2)**

**Sol.**  $\beta = \frac{1-\eta}{\eta}$   
 $= \frac{1-\frac{1}{10}}{\frac{1}{10}} = \frac{9}{10} = \frac{90}{10}$

$$\beta = 9$$

$$\beta = \frac{Q_2}{W}$$

$$Q_2 = 9 \times 10 = 90 \text{ J}$$

28. If  $\theta_1$  and  $\theta_2$  be the apparent angles of dip observed in two vertical planes at right angles to each other, then the true angle of dip  $\theta$  is given by

- (1)  $\cot^2\theta = \cot^2\theta_1 + \cot^2\theta_2$   
 (2)  $\tan^2\theta = \tan^2\theta_1 + \tan^2\theta_2$   
 (3)  $\cot^2\theta = \cot^2\theta_1 - \cot^2\theta_2$   
 (4)  $\tan^2\theta = \tan^2\theta_1 - \tan^2\theta_2$

**Answer (1)**

**Sol.**  $\cot^2\theta = \cot^2\theta_1 + \cot^2\theta_2$

29. An arrangement of three parallel straight wires placed perpendicular to plane of paper carrying same current ' $I$ ' along the same direction is shown in Fig. Magnitude of force per unit length on the middle wire 'B' is given by

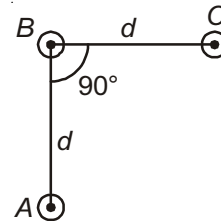

- (1)  $\frac{\mu_0 I^2}{2\pi d}$                                       (2)  $\frac{2\mu_0 I^2}{\pi d}$   
 (3)  $\frac{\sqrt{2}\mu_0 I^2}{\pi d}$                                       (4)  $\frac{\mu_0 I^2}{\sqrt{2}\pi d}$

**Answer (4)**

**Sol.** Force between BC and AB will be same in magnitude.

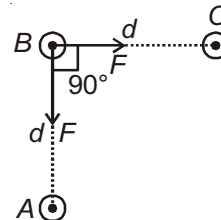

$$F_{BC} = F_{BA} = \frac{\mu_0 I^2}{2\pi d}$$

$$F = \sqrt{2} F_{BC}$$

$$= \sqrt{2} \frac{\mu_0 I^2}{2\pi d}$$

$$F = \frac{\mu_0 I^2}{\sqrt{2}\pi d}$$



30. Two astronauts are floating in gravitational free space after having lost contact with their spaceship. The two will:

- (1) Keep floating at the same distance between them
- (2) Move towards each other
- (3) Move away from each other
- (4) Will become stationary

**Answer (2)**

**Sol.** Both the astronauts are in the condition of weightlessness. Gravitational force between them pulls towards each other.

31. In an electromagnetic wave in free space the root mean square value of the electric field is  $E_{\text{rms}} = 6 \text{ V/m}$ . The peak value of the magnetic field is

- (1)  $1.41 \times 10^{-8} \text{ T}$
- (2)  $2.83 \times 10^{-8} \text{ T}$
- (3)  $0.70 \times 10^{-8} \text{ T}$
- (4)  $4.23 \times 10^{-8} \text{ T}$

**Answer (2)**

**Sol.**  $\frac{E_{\text{rms}}}{B_{\text{rms}}} = c$

$$B_{\text{rms}} = \frac{E_{\text{rms}}}{c}$$

$$= \frac{6}{3 \times 10^8}$$

$$B_{\text{rms}} = 2 \times 10^{-8}$$

$$B_{\text{rms}} = \frac{B_0}{\sqrt{2}}$$

$$B_0 = \sqrt{2} \times B_{\text{rms}}$$

$$= \sqrt{2} \times 2 \times 10^{-8}$$

$$= 2.83 \times 10^{-8} \text{ T}$$

32. The bulk modulus of a spherical object is 'B'. If it is subjected to uniform pressure 'p', the fractional decrease in radius is

- (1)  $\frac{p}{B}$
- (2)  $\frac{B}{3p}$
- (3)  $\frac{3p}{B}$
- (4)  $\frac{p}{3B}$

**Answer (4)**

**Sol.**  $B = \frac{\rho}{\left(\frac{\Delta V}{V}\right)}$

$$\frac{\Delta V}{V} = \frac{\rho}{B}$$

$$3 \frac{\Delta r}{r} = \frac{\rho}{B}$$

$$\frac{\Delta r}{r} = \frac{\rho}{3B}$$

33. The ratio of resolving powers of an optical microscope for two wavelengths  $\lambda_1 = 4000 \text{ \AA}$  and  $\lambda_2 = 6000 \text{ \AA}$  is

- (1) 8 : 27
- (2) 9 : 4
- (3) 3 : 2
- (4) 16 : 81

**Answer (3)**

**Sol.** Resolving power  $\propto \frac{1}{\lambda}$

$$\frac{R_1}{R_2} = \frac{\lambda_2}{\lambda_1}$$

$$= \frac{6000 \text{ \AA}}{4000 \text{ \AA}}$$

$$= \frac{3}{2}$$

34. Consider a drop of rain water having mass 1 g falling from a height of 1 km. It hits the ground with a speed of 50 m/s. Take  $g$  constant with a value  $10 \text{ m/s}^2$ . The work done by the (i) gravitational force and the (ii) resistive force of air is

- |                |              |
|----------------|--------------|
| (1) (i) - 10 J | (ii) -8.25 J |
| (2) (i) 1.25 J | (ii) -8.25 J |
| (3) (i) 100 J  | (ii) 8.75 J  |
| (4) (i) 10 J   | (ii) -8.75 J |

**Answer (4)**

**Sol.**  $w_g + w_a = K_f - K_i$

$$mgh + w_a = \frac{1}{2}mv^2 - 0$$

$$10^{-3} \times 10 \times 10^3 + w_a = \frac{1}{2} \times 10^{-3} \times (50)^2$$

$w_a = -8.75 \text{ J}$  i.e. work done due to air resistance and work done due to gravity = 10 J

35. A spherical black body with a radius of 12 cm radiates 450 watt power at 500 K. If the radius were halved and the temperature doubled, the power radiated in watt would be

- (1) 225 (2) 450  
 (3) 1000 (4) 1800

**Answer (4)**

**Sol.** Rate of power loss

$$r \propto R^2 T^4$$

$$\frac{r_1}{r_2} = \frac{R_1^2 T_1^4}{R_2^2 T_2^4}$$

$$= 4 \times \frac{1}{16}$$

$$\frac{450}{r_2} = \frac{1}{4}$$

$$r_2 = 1800 \text{ watt}$$

36. Two blocks A and B of masses  $3m$  and  $m$  respectively are connected by a massless and inextensible string. The whole system is suspended by a massless spring as shown in figure. The magnitudes of acceleration of A and B immediately after the string is cut, are respectively

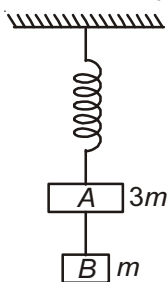

- (1)  $g, \frac{g}{3}$  (2)  $\frac{g}{3}, g$   
 (3)  $g, g$  (4)  $\frac{g}{3}, \frac{g}{3}$

**Answer (2)**

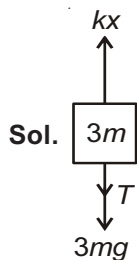

Before the string is cut

$$kx = T + 3mg \quad \dots(1)$$

$$T = mg \quad \dots(2)$$

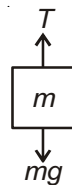

$$\Rightarrow kx = 4mg$$

After the string is cut,  $T = 0$

$$a = \frac{kx - 3mg}{3m}$$

$$a = \frac{4mg - 3mg}{3m}$$

$$a = \frac{g}{3} \uparrow$$

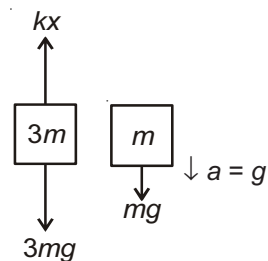

37. Two Polaroids  $P_1$  and  $P_2$  are placed with their axis perpendicular to each other. Unpolarised light  $I_0$  is incident on  $P_1$ . A third polaroid  $P_3$  is kept in between  $P_1$  and  $P_2$  such that its axis makes an angle  $45^\circ$  with that of  $P_1$ . The intensity of transmitted light through  $P_2$  is

- (1)  $\frac{I_0}{2}$   
 (2)  $\frac{I_0}{4}$   
 (3)  $\frac{I_0}{8}$   
 (4)  $\frac{I_0}{16}$

**Answer (3)**

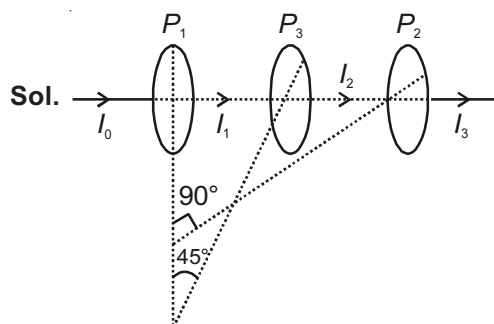

$$I_2 = \frac{I_0}{2} \cos^2 45^\circ$$

$$= \frac{I_0}{2} \times \frac{1}{2}$$

$$= \frac{I_0}{4}$$

$$I_3 = \frac{I_0}{4} \cos^2 45^\circ$$

$$I_3 = \frac{I_0}{8}$$

38. A long solenoid of diameter 0.1 m has  $2 \times 10^4$  turns per meter. At the centre of the solenoid, a coil of 100 turns and radius 0.01 m is placed with its axis coinciding with the solenoid axis. The current in the solenoid reduces at a constant rate to 0 A from 4 A in 0.05 s. If the resistance of the coil is  $10\pi^2 \Omega$ , the total charge flowing through the coil during this time is

- (1)  $32\pi \mu\text{C}$                       (2)  $16 \mu\text{C}$   
 (3)  $32 \mu\text{C}$                         (4)  $16\pi \mu\text{C}$

**Answer (3)**

**Sol.**  $\varepsilon = -N \frac{d\phi}{dt}$

$$\left| \frac{\varepsilon}{R} \right| = \frac{N d\phi}{R dt}$$

$$dq = \frac{N}{R} d\phi$$

$$\Delta Q = \frac{N(\Delta\phi)}{R}$$

$$\Delta Q = \frac{\Delta\phi_{\text{total}}}{R}$$

$$= \frac{(NBA)}{R}$$

$$= \frac{\mu_0 n i \pi r^2}{R}$$

Putting values

$$= \frac{4\pi \times 10^{-7} \times 100 \times 4 \times \pi \times (0.01)^2}{10\pi^2}$$

$$\Delta Q = 32 \mu\text{C}$$

39. Two discs of same moment of inertia rotating about their regular axis passing through centre and perpendicular to the plane of disc with angular velocities  $\omega_1$  and  $\omega_2$ . They are brought into contact face to face coinciding the axis of rotation. The expression for loss of energy during this process is

- (1)  $\frac{1}{2} I(\omega_1 + \omega_2)^2$               (2)  $\frac{1}{4} I(\omega_1 - \omega_2)^2$   
 (3)  $I(\omega_1 - \omega_2)^2$                 (4)  $\frac{I}{8}(\omega_1 - \omega_2)^2$

**Answer (2)**

**Sol.**  $\Delta KE = \frac{1}{2} \frac{I_1 I_2}{I_1 + I_2} (\omega_1 - \omega_2)^2$

$$= \frac{1}{2} \frac{I^2}{(2I)} (\omega_1 - \omega_2)^2$$

$$= \frac{1}{4} I (\omega_1 - \omega_2)^2$$

40. Preeti reached the metro station and found that the escalator was not working. She walked up the stationary escalator in time  $t_1$ . On other days, if she remains stationary on the moving escalator, then the escalator takes her up in time  $t_2$ . The time taken by her to walk up on the moving escalator will be

(1)  $\frac{t_1 + t_2}{2}$                               (2)  $\frac{t_1 t_2}{t_2 - t_1}$

(3)  $\frac{t_1 t_2}{t_2 + t_1}$                         (4)  $t_1 - t_2$

**Answer (3)**

**Sol.** Velocity of girl w.r.t. elevator =  $\frac{d}{t_1} = v_{ge}$

Velocity of elevator w.r.t. ground  $v_{eG} = \frac{d}{t_2}$  then

velocity of girl w.r.t. ground

$$\vec{v}_{gG} = \vec{v}_{ge} + \vec{v}_{eG}$$

i.e,  $v_{gG} = v_{ge} + v_{eG}$

$$\frac{d}{t} = \frac{d}{t_1} + \frac{d}{t_2}$$

$$\frac{1}{t} = \frac{1}{t_1} + \frac{1}{t_2}$$

$$t = \frac{t_1 t_2}{(t_1 + t_2)}$$

41. A rope is wound around a hollow cylinder of mass 3 kg and radius 40 cm. What is the angular acceleration of the cylinder if the rope is pulled with a force of 30 N?

- (1)  $25 \text{ m/s}^2$                         (2)  $0.25 \text{ rad/s}^2$   
 (3)  $25 \text{ rad/s}^2$                     (4)  $5 \text{ m/s}^2$

**Answer (3)**

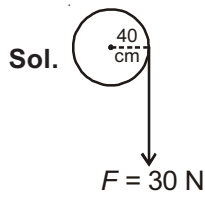

$$\tau = I \alpha$$

$$F \times R = MR^2 \alpha$$

$$30 \times 0.4 = 3 \times (0.4)^2 \alpha$$

$$12 = 3 \times 0.16 \alpha$$

$$400 = 16 \alpha$$

$$\alpha = 25 \text{ rad/s}^2$$

42. A beam of light from a source  $L$  is incident normally on a plane mirror fixed at a certain distance  $x$  from the source. The beam is reflected back as a spot on a scale placed just above the source  $L$ . When the mirror is rotated through a small angle  $\theta$ , the spot of the light is found to move through a distance  $y$  on the scale. The angle  $\theta$  is given by

- |                    |                   |
|--------------------|-------------------|
| (1) $\frac{y}{2x}$ | (2) $\frac{y}{x}$ |
| (3) $\frac{x}{2y}$ | (4) $\frac{x}{y}$ |

**Answer (1)**

**Sol.** When mirror is rotated by  $\theta$  angle reflected ray will be rotated by  $2\theta$ .

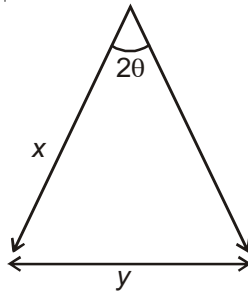

$$\frac{y}{x} = 2\theta$$

$$\theta = \frac{y}{2x}$$

43. The two nearest harmonics of a tube closed at one end and open at other end are 220 Hz and 260 Hz. What is the fundamental frequency of the system?

- |           |           |
|-----------|-----------|
| (1) 10 Hz | (2) 20 Hz |
| (3) 30 Hz | (4) 40 Hz |

**Answer (2)**

**Sol.** Two successive frequencies of closed pipe

$$\frac{nv}{4l} = 220 \quad \dots(i)$$

$$\frac{(n+2)v}{4l} = 260 \quad \dots(ii)$$

Dividing (ii) by (i), we get

$$\frac{n+2}{n} = \frac{260}{220} = \frac{13}{11}$$

$$11n + 22 = 13n$$

$$n = 11$$

$$\text{So, } 11 \frac{v}{4l} = 220$$

$$\frac{v}{4l} = 20$$

So fundamental frequency is 20 Hz.

44. A thin prism having refracting angle  $10^\circ$  is made of glass of refractive index 1.42. This prism is combined with another thin prism of glass of refractive index 1.7. This combination produces dispersion without deviation. The refracting angle of second prism should be

- |               |                |
|---------------|----------------|
| (1) $4^\circ$ | (2) $6^\circ$  |
| (3) $8^\circ$ | (4) $10^\circ$ |

**Answer (2)**

**Sol.**  $(\mu - 1)A + (\mu' - 1)A' = 0$

$$|(\mu - 1)A| = |(\mu' - 1)A'|$$

$$(1.42 - 1) \times 10^\circ = (1.7 - 1)A'$$

$$4.2 = 0.7A'$$

$$A' = 6^\circ$$

45. The resistance of a wire is ' $R$ ' ohm. If it is melted and stretched to ' $n$ ' times its original length, its new resistance will be

- |            |                     |
|------------|---------------------|
| (1) $nR$   | (2) $\frac{R}{n}$   |
| (3) $n^2R$ | (4) $\frac{R}{n^2}$ |

**Answer (3)**

**Sol.** 
$$\frac{R_2}{R_1} = \frac{l_2^2}{l_1^2}$$

$$= \frac{n^2 l_1^2}{l_1^2}$$

$$\frac{R_2}{R_1} = n^2$$

$$R_2 = n^2 R_1$$

46. With respect to the conformers of ethane, which of the following statements is true?

- (1) Bond angle remains same but bond length changes
- (2) Bond angle changes but bond length remains same
- (3) Both bond angle and bond length change
- (4) Both bond angles and bond length remains same

**Answer (4)**

**Sol.** There is no change in bond angles and bond lengths in the conformations of ethane. There is only change in dihedral angle.

47. Which of the following pairs of compounds is isoelectronic and isostructural?

- (1)  $\text{BeCl}_2$ ,  $\text{XeF}_2$
- (2)  $\text{TeI}_2$ ,  $\text{XeF}_2$
- (3)  $\text{IBr}_2^-$ ,  $\text{XeF}_2$
- (4)  $\text{IF}_3$ ,  $\text{XeF}_2$

**Answer (3)**

**Sol.**  $\text{IBr}_2^-$ ,  $\text{XeF}_2$

Total number of valence electrons are equal in both the species and both the species are linear also.

48.  $\text{HgCl}_2$  and  $\text{I}_2$  both when dissolved in water containing  $\text{I}^-$  ions the pair of species formed is

- (1)  $\text{HgI}_2$ ,  $\text{I}_3^-$
- (2)  $\text{HgI}_2$ ,  $\text{I}^-$
- (3)  $\text{HgI}_4^{2-}$ ,  $\text{I}_3^-$
- (4)  $\text{Hg}_2\text{I}_2$ ,  $\text{I}^-$

**Answer (3)**

**Sol.** In a solution containing  $\text{HgCl}_2$ ,  $\text{I}_2$  and  $\text{I}^-$ , both  $\text{HgCl}_2$  and  $\text{I}_2$  compete for  $\text{I}^-$ .

Since formation constant of  $[\text{HgI}_4]^{2-}$  is  $1.9 \times 10^{30}$  which is very large as compared with  $\text{I}_3^-$  ( $K_f = 700$ )

$\therefore \text{I}^-$  will preferentially combine with  $\text{HgCl}_2$ .

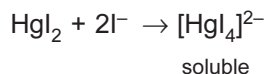
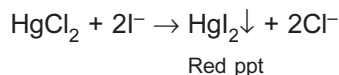

49. Mixture of chloroxylenol and terpineol acts as

- (1) Analgesic
- (2) Antiseptic
- (3) Antipyretic
- (4) Antibiotic

**Answer (2)**

**Sol.** Mixture of chloroxylenol and terpineol acts as antiseptic.

50. Which is the incorrect statement?

- (1)  $\text{FeO}_{0.98}$  has non stoichiometric metal deficiency defect
- (2) Density decreases in case of crystals with Schottky's defect
- (3)  $\text{NaCl(s)}$  is insulator, silicon is semiconductor, silver is conductor, quartz is piezo electric crystal
- (4) Frenkel defect is favoured in those ionic compounds in which sizes of cation and anions are almost equal

**Answer (1 & 4)**

**Sol.** Frenkel defect occurs in those ionic compounds in which size of cation and anion is largely different.

Non-stoichiometric ferrous oxide is  $\text{Fe}_{0.93-0.96}\text{O}_{1.00}$  and it is due to metal deficiency defect.

51. Concentration of the  $\text{Ag}^+$  ions in a saturated solution of  $\text{Ag}_2\text{C}_2\text{O}_4$  is  $2.2 \times 10^{-4} \text{ mol L}^{-1}$ . Solubility product of  $\text{Ag}_2\text{C}_2\text{O}_4$  is

- (1)  $2.42 \times 10^{-8}$
- (2)  $2.66 \times 10^{-12}$
- (3)  $4.5 \times 10^{-11}$
- (4)  $5.3 \times 10^{-12}$

**Answer (4)**

**Sol.**  $\text{Ag}_2\text{C}_2\text{O}_4(\text{s}) \rightleftharpoons 2\text{Ag}^+(\text{aq}) + \text{C}_2\text{O}_4^{2-}(\text{aq})$

$$K_{\text{SP}} = [\text{Ag}^+]^2 [\text{C}_2\text{O}_4^{2-}]$$

$$[\text{Ag}^+] = 2.2 \times 10^{-4} \text{ M}$$

$$\therefore [\text{C}_2\text{O}_4^{2-}] = \frac{2.2 \times 10^{-4}}{2} \text{ M} = 1.1 \times 10^{-4} \text{ M}$$

$$\therefore K_{\text{SP}} = (2.2 \times 10^{-4})^2 (1.1 \times 10^{-4}) = 5.324 \times 10^{-12}$$

52. Of the following, which is the product formed when cyclohexanone undergoes aldol condensation followed by heating?

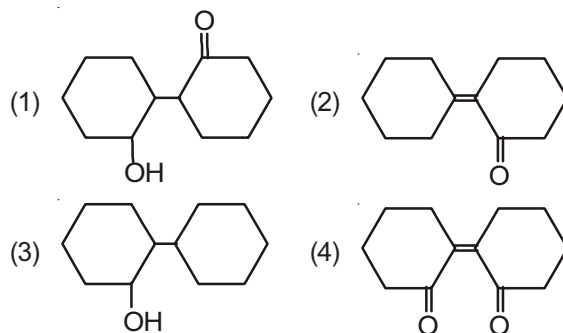

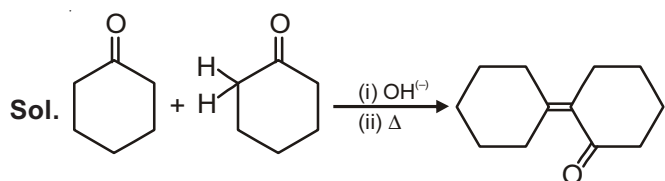
**Answer (2)**

53. The species, having bond angles of  $120^\circ$  is

- (1)  $\text{PH}_3$                       (2)  $\text{ClF}_3$   
 (3)  $\text{NCl}_3$                       (4)  $\text{BCl}_3$

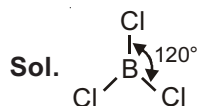
**Answer (4)**

54. If molality of the dilute solution is doubled, the value of molal depression constant ( $K_f$ ) will be

- (1) Doubled                      (2) Halved  
 (3) Tripled                      (4) Unchanged

**Answer (4)**

Sol.  $K_f$  (molal depression constant) is a characteristic of solvent and is independent of molality.

55. Which one is the most acidic compound?

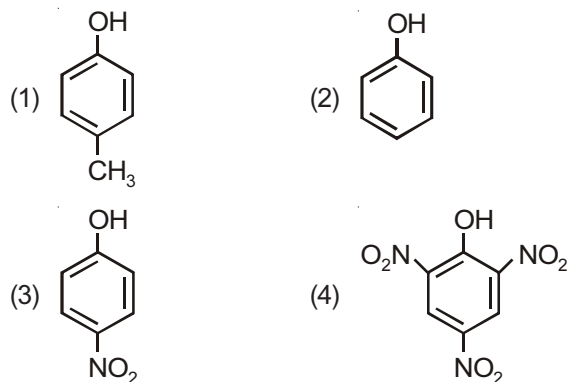
**Answer (4)**

Sol.  $-\text{NO}_2$  group has very strong  $-I$  &  $-R$  effects.

56. It is because of inability of  $ns^2$  electrons of the valence shell to participate in bonding that

- (1)  $\text{Sn}^{2+}$  is reducing while  $\text{Pb}^{4+}$  is oxidising  
 (2)  $\text{Sn}^{2+}$  is oxidising while  $\text{Pb}^{4+}$  is reducing  
 (3)  $\text{Sn}^{2+}$  and  $\text{Pb}^{2+}$  are both oxidising and reducing  
 (4)  $\text{Sn}^{4+}$  is reducing while  $\text{Pb}^{4+}$  is oxidising

**Answer (1)**

Sol. Inability of  $ns^2$  electrons of the valence shell to participate in bonding on moving down the group in heavier p-block elements is called **inert pair effect**

As a result,  $\text{Pb(II)}$  is more stable than  $\text{Pb(IV)}$

$\text{Sn(IV)}$  is more stable than  $\text{Sn(II)}$

$\therefore \text{Pb(IV)}$  is easily reduced to  $\text{Pb(II)}$

$\therefore \text{Pb(IV)}$  is oxidising agent

$\text{Sn(II)}$  is easily oxidised to  $\text{Sn(IV)}$

$\therefore \text{Sn(II)}$  is reducing agent

57. Predict the correct intermediate and product in the following reaction

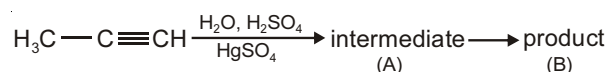

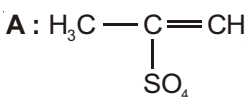
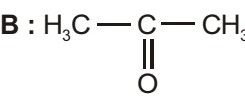
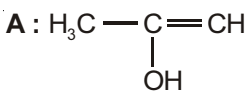
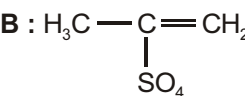
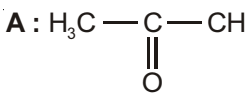
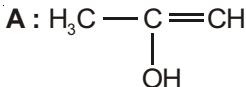
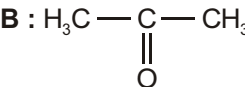
- (1) **A** :                       **B** :   
 (2) **A** :                       **B** :   
 (3) **A** :                       **B** :  $\text{H}_3\text{C}-\text{C}\equiv\text{CH}$   
 (4) **A** :                       **B** : 

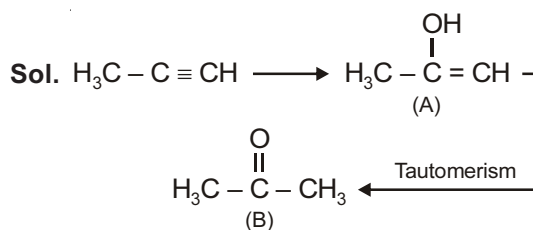
**Answer (4)**

58. Which one of the following statements is not correct?

- (1) Catalyst does not initiate any reaction  
 (2) The value of equilibrium constant is changed in the presence of a catalyst in the reaction at equilibrium  
 (3) Enzymes catalyse mainly bio-chemical reactions  
 (4) Coenzymes increase the catalytic activity of enzyme

**Answer (2)**

Sol. A catalyst decreases activation energies of both the forward and backward reaction by same amount, therefore, it speeds up both forward and backward reaction by same rate.

Equilibrium constant is therefore not affected by catalyst at a given temperature.



63. In the electrochemical cell :

$\text{Zn}|\text{ZnSO}_4(0.01\text{M})||\text{CuSO}_4(1.0\text{M})|\text{Cu}$ , the emf of this Daniel cell is  $E_1$ . When the concentration of  $\text{ZnSO}_4$  is changed to 1.0 M and that of  $\text{CuSO}_4$  changed to 0.01 M, the emf changes to  $E_2$ . From the following, which one is the relationship between  $E_1$  and  $E_2$ ?

(Given,  $\frac{RT}{F} = 0.059$ )

- (1)  $E_1 = E_2$                       (2)  $E_1 < E_2$   
 (3)  $E_1 > E_2$                       (4)  $E_2 = 0 \neq E_1$

**Answer (3)**

**Sol.**  $\text{Zn}|\text{ZnSO}_4(0.01\text{M})||\text{CuSO}_4(1.0\text{M})|\text{Cu}$

$$\therefore E_1 = E_{\text{cell}}^{\circ} - \frac{2.303RT}{2 \times F} \times \log \frac{(0.01)}{1}$$

When concentrations are changed

$$\therefore E_2 = E_{\text{cell}}^{\circ} - \frac{2.303RT}{2F} \times \log \frac{1}{0.01}$$

i.e.,  $E_1 > E_2$

64. The correct increasing order of basic strength for the following compounds is

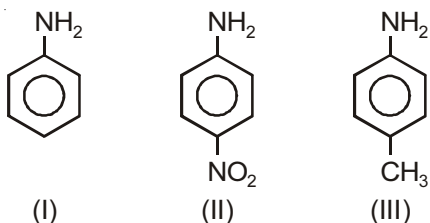

- (1)  $\text{II} < \text{III} < \text{I}$                       (2)  $\text{III} < \text{I} < \text{II}$   
 (3)  $\text{III} < \text{II} < \text{I}$                       (4)  $\text{II} < \text{I} < \text{III}$

**Answer (4)**

**Sol.**  $-\text{NO}_2$  has strong  $-\text{R}$  effect and  $-\text{CH}_3$  shows  $+\text{R}$  effect.

$\therefore$  Order of basic strength is

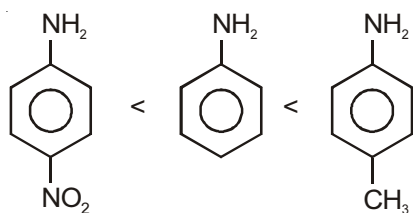

65. In which pair of ions both the species contain S – S bond?

- (1)  $\text{S}_2\text{O}_7^{2-}$ ,  $\text{S}_2\text{O}_3^{2-}$                       (2)  $\text{S}_4\text{O}_6^{2-}$ ,  $\text{S}_2\text{O}_3^{2-}$   
 (3)  $\text{S}_2\text{O}_7^{2-}$ ,  $\text{S}_2\text{O}_8^{2-}$                       (4)  $\text{S}_4\text{O}_6^{2-}$ ,  $\text{S}_2\text{O}_7^{2-}$

**Answer (2)**

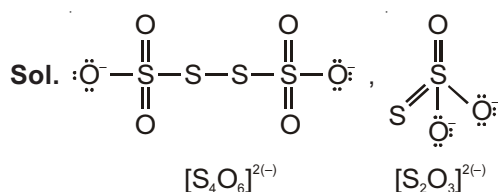

66. The correct order of the stoichiometries of  $\text{AgCl}$  formed when  $\text{AgNO}_3$  in excess is treated with the complexes :  $\text{CoCl}_3 \cdot 6\text{NH}_3$ ,  $\text{CoCl}_3 \cdot 5\text{NH}_3$ ,  $\text{CoCl}_3 \cdot 4\text{NH}_3$  respectively is

- (1) 1  $\text{AgCl}$ , 3  $\text{AgCl}$ , 2  $\text{AgCl}$   
 (2) 3  $\text{AgCl}$ , 1  $\text{AgCl}$ , 2  $\text{AgCl}$   
 (3) 3  $\text{AgCl}$ , 2  $\text{AgCl}$ , 1  $\text{AgCl}$   
 (4) 2  $\text{AgCl}$ , 3  $\text{AgCl}$ , 1  $\text{AgCl}$

**Answer (3)**

**Sol.** Complexes are respectively  $[\text{Co}(\text{NH}_3)_6]\text{Cl}_3$ ,  $[\text{Co}(\text{NH}_3)_5\text{Cl}]\text{Cl}_2$  and  $[\text{Co}(\text{NH}_3)_4\text{Cl}_2]\text{Cl}$

67. Match the interhalogen compounds of column I with the geometry in column II and assign the correct code

Column I	Column II
(a) $\text{XX}'$	(i) T-shape
(b) $\text{XX}'_3$	(ii) Pentagonal bipyramidal
(c) $\text{XX}'_5$	(iii) Linear
(d) $\text{XX}'_7$	(iv) Square-pyramidal
	(v) Tetrahedral

**Code :**

	(a)	(b)	(c)	(d)
(1)	(iii)	(iv)	(i)	(ii)
(2)	(iii)	(i)	(iv)	(ii)
(3)	(v)	(iv)	(iii)	(ii)
(4)	(iv)	(iii)	(ii)	(i)

**Answer (2)**

**Sol.**  $\text{XX}' \rightarrow$  Linear

$\text{XX}'_3 \rightarrow$  Example :  $\text{ClF}_3 \rightarrow$  T-shape

$\text{XX}'_5 \rightarrow$  Example :  $\text{BrF}_5 \rightarrow$  Square pyramidal

$\text{XX}'_7 \rightarrow$  Example :  $\text{IF}_7 \rightarrow$  Pentagonal bipyramidal



68. The reason for greater range of oxidation states in actinoids is attributed to
- (1) The radioactive nature of actinoids
  - (2) Actinoid contraction
  - (3)  $5f$ ,  $6d$  and  $7s$  levels having comparable energies
  - (4)  $4f$  and  $5d$  levels being close in energies

**Answer (3)**

**Sol.** It is a fact.

69. A 20 litre container at 400 K contains  $\text{CO}_2(\text{g})$  at pressure 0.4 atm and an excess of SrO (neglect the volume of solid SrO). The volume of the container is now decreased by moving the movable piston fitted in the container. The maximum volume of the container, when pressure of  $\text{CO}_2$  attains its maximum value, will be

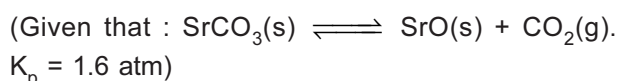

- (1) 5 litre
- (2) 10 litre
- (3) 4 litre
- (4) 2 litre

**Answer (1)**

**Sol.** Max. pressure of  $\text{CO}_2 =$  Pressure of  $\text{CO}_2$  at equilibrium

For reaction,

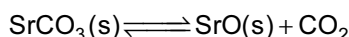

$$K_p = P_{\text{CO}_2} = 1.6 \text{ atm} = \text{maximum pressure of } \text{CO}_2$$

Volume of container at this stage,

$$V = \frac{nRT}{P} \quad \dots(\text{i})$$

Since container is sealed and reaction was not earlier at equilibrium

$\therefore n = \text{constant}$

$$n = \frac{PV}{RT} = \frac{0.4 \times 20}{RT} \quad \dots(\text{ii})$$

Put equation (ii) in equation (i)

$$V = \left[ \frac{0.4 \times 20}{RT} \right] \frac{RT}{1.6} = 5 \text{ L}$$

70. The correct statement regarding electrophile is
- (1) Electrophile is a negatively charged species and can form a bond by accepting a pair of electrons from a nucleophile
  - (2) Electrophile is a positively charged species and can form a bond by accepting a pair of electrons from another electrophile

- (3) Electrophiles are generally neutral species and can form a bond by accepting a pair of electrons from a nucleophile
- (4) Electrophile can be either neutral or positively charged species and can form a bond by accepting a pair of electrons from a nucleophile

**Answer (4)**

**Sol.** Fact.

71. Which of the following is a sink for  $\text{CO}$ ?

- (1) Haemoglobin
- (2) Micro-organisms present in the soil
- (3) Oceans
- (4) Plants

**Answer (2)**

**Sol.** Micro-organisms present in the soil is a sink for  $\text{CO}$ .

72. The element  $Z = 114$  has been discovered recently. It will belong to which of the following family group and electronic configuration?

- (1) Halogen family,  $[\text{Rn}] 5f^{14}6d^{10}7s^27p^5$
- (2) Carbon family,  $[\text{Rn}] 5f^{14}6d^{10}7s^27p^2$
- (3) Oxygen family,  $[\text{Rn}] 5f^{14}6d^{10}7s^27p^4$
- (4) Nitrogen family,  $[\text{Rn}] 5f^{14}6d^{10}7s^27p^6$

**Answer (2)**

**Sol.**  $Z = 114$  belong to Group 14, carbon family

$$\text{Electronic configuration} = [\text{Rn}]5f^{14}6d^{10}7s^27p^2$$

73. Correct increasing order for the wavelengths of absorption in the visible region for the complexes of  $\text{Co}^{3+}$  is

- (1)  $[\text{Co}(\text{en})_3]^{3+}$ ,  $[\text{Co}(\text{NH}_3)_6]^{3+}$ ,  $[\text{Co}(\text{H}_2\text{O})_6]^{3+}$
- (2)  $[\text{Co}(\text{H}_2\text{O})_6]^{3+}$ ,  $[\text{Co}(\text{en})_3]^{3+}$ ,  $[\text{Co}(\text{NH}_3)_6]^{3+}$
- (3)  $[\text{Co}(\text{H}_2\text{O})_6]^{3+}$ ,  $[\text{Co}(\text{NH}_3)_6]^{3+}$ ,  $[\text{Co}(\text{en})_3]^{3+}$
- (4)  $[\text{Co}(\text{NH}_3)_6]^{3+}$ ,  $[\text{Co}(\text{en})_3]^{3+}$ ,  $[\text{Co}(\text{H}_2\text{O})_6]^{3+}$

**Answer (1)**

**Sol.** The order of the ligand in the spectrochemical series



Hence, the wavelength of the light observed will be in the order

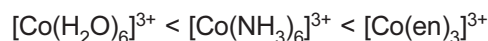

Thus, wavelength absorbed will be in the opposite order



74. Which of the following statements is not correct?
- (1) Insulin maintains sugar level in the blood of a human body
  - (2) Ovalbumin is a simple food reserve in egg-white
  - (3) Blood proteins thrombin and fibrinogen are involved in blood clotting
  - (4) Denaturation makes the proteins more active

**Answer (4)**

**Sol.** Due to denaturation of proteins, globules unfold and helix get uncoiled and protein loses its biological activity.

75. An example of a sigma bonded organometallic compound is :
- (1) Ruthenocene
  - (2) Grignard's reagent
  - (3) Ferrocene
  - (4) Cobaltocene

**Answer (2)**

**Sol.** Grignard's reagent *i.e.*, RMgX is  $\sigma$ -bonded organometallic compound.

76. Which of the following is dependent on temperature?
- (1) Molality
  - (2) Molarity
  - (3) Mole fraction
  - (4) Weight percentage

**Answer (2)**

**Sol.** Molarity includes volume of solution which can change with change in temperature.

77. For a given reaction,  $\Delta H = 35.5 \text{ kJ mol}^{-1}$  and  $\Delta S = 83.6 \text{ JK}^{-1} \text{ mol}^{-1}$ . The reaction is spontaneous at : (Assume that  $\Delta H$  and  $\Delta S$  do not vary with temperature)
- (1)  $T < 425 \text{ K}$
  - (2)  $T > 425 \text{ K}$
  - (3) All temperatures
  - (4)  $T > 298 \text{ K}$

**Answer (2)**

**Sol.**  $\therefore \Delta G = \Delta H - T\Delta S$

For a reaction to be spontaneous,  $\Delta G = -ve$   
*i.e.*,  $\Delta H < T\Delta S$

$$\therefore T > \frac{\Delta H}{\Delta S} = \frac{35.5 \times 10^3 \text{ J}}{83.6 \text{ JK}^{-1}}$$

*i.e.*,  $T > 425 \text{ K}$

78. The most suitable method of separation of 1 : 1 mixture of ortho and para-nitrophenols is
- (1) Sublimation
  - (2) Chromatography
  - (3) Crystallisation
  - (4) Steam distillation

**Answer (4)**

**Sol.** Steam distillation is the most suitable method of separation of 1 : 1 mixture of ortho and para nitrophenols as there is intramolecular H-bonds in ortho nitrophenol.

79. Which one of the following pairs of species have the same bond order?
- (1) CO, NO
  - (2)  $\text{O}_2$ ,  $\text{NO}^+$
  - (3)  $\text{CN}^-$ , CO
  - (4)  $\text{N}_2$ ,  $\text{O}_2^-$

**Answer (3)**

**Sol.**  $\text{CN}^-$  and CO have bond order 3 each.

80. Identify A and predict the type of reaction

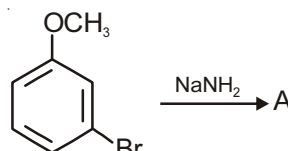

- (1) and substitution reaction
- (2) and elimination addition reaction
- (3) and cine substitution reaction
- (4) and cine substitution reaction

**Answer (1)**

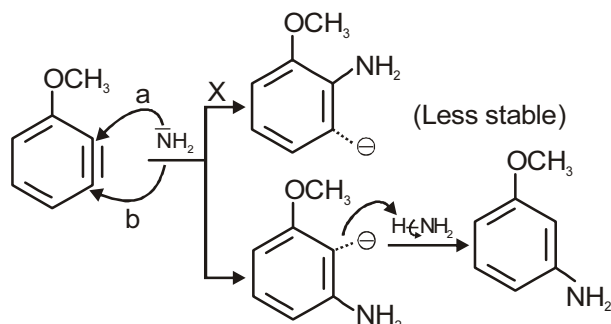
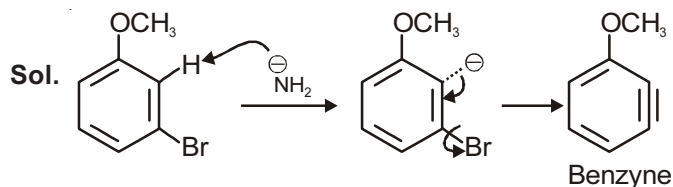

More stable as -ve charge is close to electron withdrawing group

∴ Incoming nucleophile ends on same 'C' on which 'Br' (Leaving group) was present

∴ **NOT** cine substitution.

81. A first order reaction has a specific reaction rate of  $10^{-2} \text{ s}^{-1}$ . How much time will it take for 20 g of the reactant to reduce to 5 g?

- (1) 238.6 second                      (2) 138.6 second  
(3) 346.5 second                      (4) 693.0 second

**Answer (2)**

**Sol.**  $t_{1/2} = \frac{0.693}{10^{-2}} \text{ second}$

For the reduction of 20 g of reactant to 5 g, two  $t_{1/2}$  is required.

∴  $t = 2 \times \frac{0.693}{10^{-2}} \text{ second}$   
 $= 138.6 \text{ second}$

82. Name the gas that can readily decolourises acidified  $\text{KMnO}_4$  solution:

- (1)  $\text{CO}_2$                                       (2)  $\text{SO}_2$   
(3)  $\text{NO}_2$                                       (4)  $\text{P}_2\text{O}_5$

**Answer (2)**

**Sol.**  $\text{SO}_2$  is readily decolourises acidified  $\text{KMnO}_4$ .

83. The heating of phenyl-methyl ethers with HI produces.

- (1) Ethyl chlorides  
(2) Iodobenzene  
(3) Phenol  
(4) Benzene

**Answer (3)**

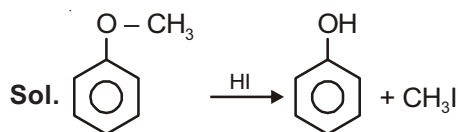

84. Pick out the correct statement with respect  $[\text{Mn}(\text{CN})_6]^{3-}$  :

- (1) It is  $sp^3d^2$  hybridised and octahedral  
(2) It is  $sp^3d^2$  hybridised and tetrahedral  
(3) It is  $d^2sp^3$  hybridised and octahedral  
(4) It is  $dsp^2$  hybridised and square planar

**Answer (3)**

**Sol.**  $[\text{Mn}(\text{CN})_6]^{3-}$

$\text{Mn(III)} = [\text{Ar}]3d^4$

$\text{CN}^-$  being strong field ligand forces pairing of electrons

This gives  $t_{2g}^4 e_g^0$

∴  $\text{Mn(III)} = [\text{Ar}]$

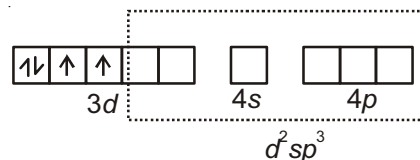

∴ Coordination number of Mn = 6

∴ Structure = octahedral

$[\text{Mn}(\text{CN})_6]^{3-} =$

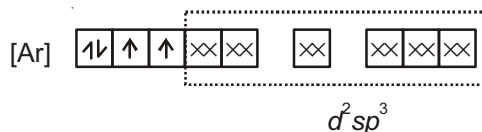

85. Ionic mobility of which of the following alkali metal ions is lowest when aqueous solution of their salts are put under an electric field?

- (1) Na    (2) K  
(3) Rb    (4) Li

**Answer (4)**

**Sol.**  $\text{Li}^+$  being smallest, has maximum charge density

∴  $\text{Li}^+$  is most heavily hydrated among all alkali metal ions. Effective size of  $\text{Li}^+$  in aq solution is therefore, largest.

∴ Moves slowest under electric field.

86. The equilibrium constants of the following are.

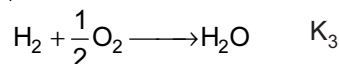
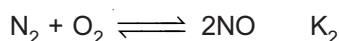
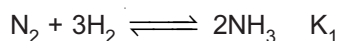

The equilibrium constant (K) of the reaction:

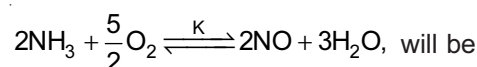

- (1)  $K_1K_3^3 / K_2$                                       (2)  $K_2K_3^3 / K_1$   
(3)  $K_2K_3 / K_1$                                       (4)  $K_2^3K_3 / K_1$

**Answer (2)**

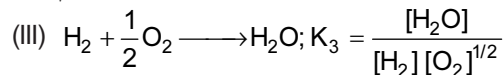
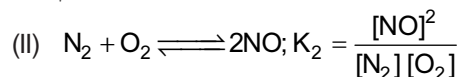
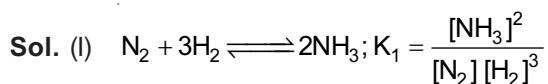

(II + 3 × III – II) will give

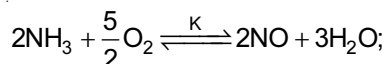

$$\therefore K = K_2 \times K_3^3 / K_1$$

87. Which of the following reactions is appropriate for converting acetamide to methanamine?

- (1) Carbylamine reaction
- (2) Hoffmann hypobromamide reaction
- (3) Stephens reaction
- (4) Gabriels phthalimide synthesis

Answer (2)

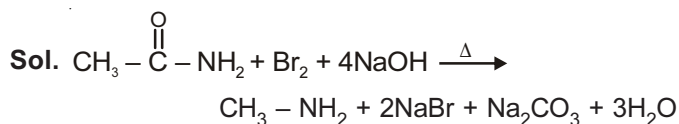

This is Hoffmann Bromamide reaction.

88. Mechanism of a hypothetical reaction  $X_2 + Y_2 \rightarrow 2XY$  is given below :

- (i)  $X_2 \rightarrow X + X$  (fast)
- (ii)  $X + Y_2 \rightleftharpoons XY + Y$  (slow)
- (iii)  $X + Y \rightarrow XY$  (fast)

The overall order of the reaction will be

- (1) 1
- (2) 2
- (3) 0
- (4) 1.5

Answer (4)

Sol. The solution of this question is given by assuming step (i) to be reversible which is not given in question

$$\text{Overall rate} = \text{Rate of slowest step (ii)} \\ = k[X][Y_2] \quad \dots(1)$$

k = rate constant of step (ii)

Assuming step (i) to be reversible, its equilibrium constant,

$$k_{eq} = \frac{[X]^2}{[X_2]} \Rightarrow [X] = k_{eq}^{1/2} [X_2]^{1/2} \quad \dots(2)$$

Put (2) in (1)

$$\text{Rate} = k k_{eq}^{1/2} [X_2]^{1/2} [Y_2]$$

$$\text{Overall order} = \frac{1}{2} + 1 = \frac{3}{2}$$

89. The IUPAC name of the compound

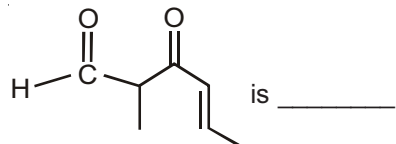

- (1) 3-keto-2-methylhex-4-enal
- (2) 5-formylhex-2-en-3-one
- (3) 5-methyl-4-oxohex-2-en-5-al
- (4) 3-keto-2-methylhex-5-enal

Answer (1)

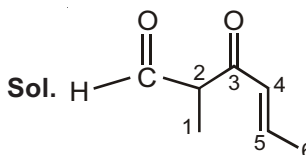

Aldehydes get higher priority over ketone and alkene in numbering of principal C-chain.

$\therefore$  3-keto-2-methylhex-4-enal

90. Extraction of gold and silver involves leaching with  $CN^-$  ion. Silver is later recovered by

- (1) Liquation
- (2) Distillation
- (3) Zone refining
- (4) Displacement with Zn

Answer (4)

Sol. Zn being more reactive than Ag and Au, displaces them.

From Native ore,

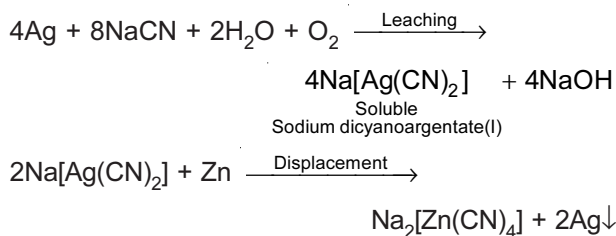

91. Double fertilization is exhibited by  
(1) Gymnosperms (2) Algae  
(3) Fungi (4) Angiosperms

**Answer (4)**

**Sol.** Double fertilization is a characteristic feature exhibited by angiosperms. It involves syngamy and triple fusion.

92. Which of the following are found in extreme saline conditions?  
(1) Archaeobacteria  
(2) Eubacteria  
(3) Cyanobacteria  
(4) Mycobacteria

**Answer (1)**

**Sol.** Archaeobacteria are able to survive in harsh conditions because of branched lipid chain in cell membrane which reduces fluidity of cell membrane.

Halophiles are exclusively found in saline habitats.

93. Select the mismatch :  
(1) *Frankia* – *Alnus*  
(2) *Rhodospirillum* – *Mycorrhiza*  
(3) *Anabaena* – Nitrogen fixer  
(4) *Rhizobium* – *Alfalfa*

**Answer (2)**

**Sol.** *Rhodospirillum* is anaerobic, free living nitrogen fixer. Mycorrhiza is a symbiotic relationship between fungi and roots of higher plants.

94. What is the criterion for DNA fragments movement on agarose gel during gel electrophoresis?  
(1) The larger the fragment size, the farther it moves  
(2) The smaller the fragment size, the farther it moves  
(3) Positively charged fragments move to farther end  
(4) Negatively charged fragments do not move

**Answer (2)**

**Sol.** During gel electrophoresis, DNA fragments separate (resolve) according to their size through sieving effect provided by agarose gel.

95. Attractants and rewards are required for  
(1) Anemophily  
(2) Entomophily  
(3) Hydrophily  
(4) Cleistogamy

**Answer (2)**

**Sol.** Insect pollinated plants provide rewards as edible pollen grain and nectar as usual rewards. While some plants also provide safe place for deposition of eggs.

96. Which of the following is made up of dead cells?  
(1) Xylem parenchyma (2) Collenchyma  
(3) Phellem (4) Phloem

**Answer (3)**

**Sol.** Cork cambium undergoes periclinal division and cuts off thick walled suberised dead cork cells towards outside and it cuts off thin walled living cells i.e., phelloderm on inner side.

97. Which cells of 'Crypts of Lieberkuhn' secrete antibacterial lysozyme?  
(1) Argentaffin cells (2) Paneth cells  
(3) Zymogen cells (4) Kupffer cells

**Answer (2)**

**Sol.** – Kupffer-cells are phagocytic cells of liver.  
– Zymogen cells are enzyme producing cells.  
– Paneth cell secretes lysozyme which acts as anti-bacterial agent.  
– Argentaffin cells are hormone producing cells.

98. Adult human RBCs are enucleate. Which of the following statement(s) is/are most appropriate explanation for this feature?  
(a) They do not need to reproduce  
(b) They are somatic cells  
(c) They do not metabolize  
(d) All their internal space is available for oxygen transport  
(1) Only (d) (2) Only (a)  
(3) (a), (c) and (d) (4) (b) and (c)

**Answer (1)**

**Sol.** In Human RBCs, nucleus degenerates during maturation which provide more space for oxygen carrying pigment (Haemoglobin). It lacks most of the cell organelles including mitochondria so respire anaerobically.

99. The hepatic portal vein drains blood to liver from  
(1) Heart  
(2) Stomach  
(3) Kidneys  
(4) Intestine

**Answer (4)**

**Sol.** In hepatic portal system, hepatic portal vein carries maximum amount of nutrients from intestine to liver.

100. The final proof for DNA as the genetic material came from the experiments of

- (1) Griffith
- (2) Hershey and Chase
- (3) Avery, Mcleod and McCarty
- (4) Hargobind Khorana

**Answer (2)**

**Sol.** Hershey and Chase gave unequivocal proof which ended the debate between protein and DNA as genetic material.

101. Which among the following are the smallest living cells, known without a definite cell wall, pathogenic to plants as well as animals and can survive without oxygen?

- (1) *Bacillus*
- (2) *Pseudomonas*
- (3) *Mycoplasma*
- (4) *Nostoc*

**Answer (3)**

**Sol.** Mycoplasmas are smallest, wall-less prokaryotes, pleomorphic in nature. These are pathogenic on both plants and animals.

102. Which of the following options gives the correct sequence of events during mitosis?

- (1) Condensation → nuclear membrane disassembly → crossing over → segregation → telophase
- (2) Condensation → nuclear membrane disassembly → arrangement at equator → centromere division → segregation → telophase
- (3) Condensation → crossing over → nuclear membrane disassembly → segregation → telophase
- (4) Condensation → arrangement at equator → centromere division → segregation → telophase

**Answer (2)**

**Sol.** The correct sequence of events during mitosis would be as follows

- (i) Condensation of DNA so that chromosomes become visible occurs during early to mid-prophase.
- (ii) Nuclear membrane disassembly begins at late prophase or transition to metaphase.
- (iii) Arrangement of chromosomes at equator occurs during metaphase, called congression.
- (iv) Centromere division or splitting occurs during anaphase forming daughter chromosomes.

(v) Segregation also occurs during anaphase as daughter chromosomes separate and move to opposite poles.

(vi) Telophase leads to formation of two daughter nuclei.

103. Which one of the following statements is **correct**, with reference to enzymes?

- (1) Apoenzyme = Holoenzyme + Coenzyme
- (2) Holoenzyme = Apoenzyme + Coenzyme
- (3) Coenzyme = Apoenzyme + Holoenzyme
- (4) Holoenzyme = Coenzyme + Cofactor

**Answer (2)**

**Sol.** Holoenzyme is conjugated enzyme in which protein part is apoenzyme while non-protein is cofactor.

Coenzyme are also organic compounds but their association with apoenzyme is only transient and serve as cofactors.

104. During DNA replication, Okazaki fragments are used to elongate

- (1) The leading strand towards replication fork
- (2) The lagging strand towards replication fork
- (3) The leading strand away from replication fork
- (4) The lagging strand away from the replication fork

**Answer (4)**

**Sol.** Two DNA polymerase molecules work simultaneous at the DNA fork, one on the leading strand and the other on the lagging strand.

Each Okazaki fragment is synthesized by DNA polymerase at lagging strand in 5' → 3' direction. New Okazaki fragments appear as the replication fork opens further.

As the first Okazaki fragment appears away from the replication fork, the direction of elongation would be away from replication fork.

105. Which of the following are not polymeric?

- (1) Nucleic acids
- (2) Proteins
- (3) Polysaccharides
- (4) Lipids

**Answer (4)**

**Sol.** – Nucleic acids are polymers of nucleotides

– Proteins are polymers of amino acids

– Polysaccharides are polymers of monosaccharides

– Lipids are the esters of fatty acids and alcohol



106. The region of Biosphere Reserve which is legally protected and where no human activity is allowed is known as

- (1) Core zone                      (2) Buffer zone
- (3) Transition zone              (4) Restoration zone

**Answer (1)**

**Sol.** Biosphere reserve is protected area with multipurpose activities.

It has three zones

- (a) Core zone – without any human interference
- (b) Buffer zone – with limited human activity
- (c) Transition zone – human settlement, grazing cultivation etc., are allowed.

107. A dioecious flowering plant prevents both:

- (1) Autogamy and xenogamy
- (2) Autogamy and geitonogamy
- (3) Geitonogamy and xenogamy
- (4) Cleistogamy and xenogamy

**Answer (2)**

**Sol.** When unisexual male and female flowers are present on different plants the condition is called dioecious and it prevents both autogamy and geitonogamy.

108. A temporary endocrine gland in the human body is

- (1) Pineal gland                      (2) Corpus cardiacum
- (3) Corpus luteum                      (4) Corpus allatum

**Answer (3)**

**Sol.** Corpus luteum is the temporary endocrine structure formed in the ovary after ovulation. It is responsible for the release of the hormones like progesterone, oestrogen etc.

109. Match the following sexually transmitted diseases (Column - I) with their causative agent (Column - II) and select the correct option.

**Column - I**

- (a) Gonorrhoea
- (b) Syphilis
- (c) Genital Warts
- (d) AIDS

**Column- II**

- (i) HIV
- (ii) *Neisseria*
- (iii) *Treponema*
- (iv) *Human Papilloma virus*

**Options :**

- |           |       |       |      |
|-----------|-------|-------|------|
| (a)       | (b)   | (c)   | (d)  |
| (1) (ii)  | (iii) | (iv)  | (i)  |
| (2) (iii) | (iv)  | (i)   | (ii) |
| (3) (iv)  | (ii)  | (iii) | (i)  |
| (4) (iv)  | (iii) | (ii)  | (i)  |

**Answer (1)**

**Sol.** Gonorrhoea – *Neisseria* (Bacteria)

Syphilis – *Treponema* (Bacteria)

Genital Warts – *Human papilloma virus* (Virus)

AIDS – HIV (Virus)

110. Transplantation of tissues/organs fails often due to non-acceptance by the patient's body. Which type of immune-response is responsible for such rejections?

- (1) Autoimmune response
- (2) Cell-mediated immune response
- (3) Hormonal immune response
- (4) Physiological immune response

**Answer (2)**

**Sol.** Non-acceptance or rejection of graft or transplanted tissues/organs is due to cell mediated immune response.

111. Spliceosomes are **not** found in cells of

- (1) Plants                              (2) Fungi
- (3) Animals                              (4) Bacteria

**Answer (4)**

**Sol.** Spliceosomes are used in removal of introns during post-transcriptional processing of hnRNA in eukaryotes only as split genes are absent as prokaryotes.

112. An example of colonial alga is

- (1) *Chlorella*                              (2) *Volvox*
- (3) *Ulothrix*                              (4) *Spirogyra*

**Answer (2)**

**Sol.** *Volvox* is motile colonial fresh water alga with definite number of vegetative cells.

113. Which of the following represents order of 'Horse'?

- (1) Equidae                              (2) Perissodactyla
- (3) Caballus                              (4) Ferus

**Answer (2)**

**Sol.** Horse belongs to order perissodactyla of class mammalia. Perissodactyla includes odd-toed mammals.

114. Which of the following cell organelles is responsible for extracting energy from carbohydrates to form ATP?

- (1) Lysosome                              (2) Ribosome
- (3) Chloroplast                              (4) Mitochondrion

**Answer (4)**

**Sol.** Mitochondria are the site of aerobic oxidation of carbohydrates to generate ATP.

115. The process of separation and purification of expressed protein before marketing is called

- (1) Upstream processing
- (2) Downstream processing
- (3) Bioprocessing
- (4) Postproduction processing

**Answer (2)**

**Sol.** Biosynthetic stage for synthesis of product in recombinant DNA technology is called upstreaming process while after completion of biosynthetic stage, the product has to be subjected through a series of processes which include separation and purification are collectively referred to as downstreaming processing.

116. Mycorrhizae are the example of

- (1) Fungistasis
- (2) Amensalism
- (3) Antibiosis
- (4) Mutualism

**Answer (4)**

**Sol.** Mycorrhizae is a symbiotic association of fungi with roots of higher plants.

117. Viroids differ from viruses in having :

- (1) DNA molecules with protein coat
- (2) DNA molecules without protein coat
- (3) RNA molecules with protein coat
- (4) RNA molecules without protein coat

**Answer (4)**

**Sol.** Viroids are sub-viral agents as infectious RNA particles, without protein coat.

118. Root hairs develop from the region of

- (1) Maturation
- (2) Elongation
- (3) Root cap
- (4) Meristematic activity

**Answer (1)**

**Sol.** In roots, the root hairs arise from zone of maturation. This zone is differentiated zone thus bearing root hairs.

119. Coconut fruit is a

- (1) Drupe
- (2) Berry
- (3) Nut
- (4) Capsule

**Answer (1)**

**Sol.** Coconut fruit is a drupe. A drupe develops from monocarpellary superior ovary and are one seeded.

120. Plants which produce characteristic pneumatophores and show vivipary belong to

- (1) Mesophytes
- (2) Halophytes
- (3) Psammophytes
- (4) Hydrophytes

**Answer (2)**

**Sol.** Halophytes growing in saline soils show

- (i) Vivipary which is *in-situ* seed germination
- (ii) Pneumatophores for gaseous exchange

121. Which one of the following is related to *Ex-situ* conservation of threatened animals and plants?

- (1) Wildlife Safari parks
- (2) Biodiversity hot spots
- (3) Amazon rainforest
- (4) Himalayan region

**Answer (1)**

**Sol.** *Ex-situ* conservation is offsite strategy for conservation of animals and plants in zoological park and botanical gardens respectively.

122. Select the mismatch :

- (1) *Pinus* – Dioecious
- (2) *Cycas* – Dioecious
- (3) *Salvinia* – Heterosporous
- (4) *Equisetum* – Homosporous

**Answer (1)**

**Sol.** *Pinus* is monoecious plant having both male and female cones on same plant.

123. Which of the following facilitates opening of stomatal aperture?

- (1) Contraction of outer wall of guard cells
- (2) Decrease in turgidity of guard cells
- (3) Radial orientation of cellulose microfibrils in the cell wall of guard cells
- (4) Longitudinal orientation of cellulose microfibrils in the cell wall of guard cells

**Answer (3)**

**Sol.** Cellulose microfibrils are oriented radially rather than longitudinally which makes easy for the stoma to open.

124. The association of histone H1 with a nucleosome indicates:

- (1) Transcription is occurring
- (2) DNA replication is occurring
- (3) The DNA is condensed into a Chromatin Fibre
- (4) The DNA double helix is exposed

**Answer (3)**

**Sol.** The association of H1 protein indicates the complete formation of nucleosome.

Therefore the DNA is in condensed form.



125. DNA fragments are

- (1) Positively charged
- (2) Negatively charged
- (3) Neutral
- (4) Either positively or negatively charged depending on their size

**Answer (2)**

**Sol.** DNA fragments are negatively charged because of phosphate group.

126. Capacitation occurs in

- (1) Rete testis
- (2) Epididymis
- (3) Vas deferens
- (4) Female Reproductive tract

**Answer (4)**

**Sol.** Capacitation is increase in fertilising capacity of sperms which occurs in female reproductive tract.

127. Which ecosystem has the maximum biomass?

- (1) Forest ecosystem      (2) Grassland ecosystem
- (3) Pond ecosystem      (4) Lake ecosystem

**Answer (1)**

**Sol.** High productive ecosystem are

- Tropical rain forest
- Coral reef
- Estuaries
- Sugarcane fields

128. A disease caused by an autosomal primary non-disjunction is

- (1) Down's syndrome      (2) Klinefelter's syndrome
- (3) Turner's syndrome      (4) Sickle cell anemia

**Answer (1)**

**Sol.** Down's syndrome is caused by non-disjunction of 21<sup>st</sup> chromosome.

129. Life cycle of *Ectocarpus* and *Fucus* respectively are

- (1) Haplontic, Diplontic
- (2) Diplontic, Haplodiplontic
- (3) Haplodiplontic, Diplontic
- (4) Haplodiplontic, Haplontic

**Answer (3)**

**Sol.** *Ectocarpus* has haplodiplontic life cycle and *Fucus* has diplontic life cycle.

protein with 333 amino acids, and the base at position 901 is deleted such that the length of the RNA becomes 998 bases, how many codons will be altered?

- (1) 1                                      (2) 11
- (3) 33                                      (4) 333

**Answer (3)**

**Sol.** If deletion occurs at 901<sup>st</sup> position the remaining 98 bases specifying for 33 codons of amino acids will be altered.

131. The pivot joint between atlas and axis is a type of

- (1) Fibrous joint                      (2) Cartilaginous joint
- (3) Synovial joint                      (4) Saddle joint

**Answer (3)**

**Sol.** Synovial joints are freely movable joint which allow considerable movements. Pivot joint is a type of synovial joint which provide rotational movement as in between atlas and axis vertebrae of vertebral column.

132. A gene whose expression helps to identify transformed cell is known as

- (1) Selectable marker      (2) Vector
- (3) Plasmid                      (4) Structural gene

**Answer (1)**

**Sol.** In recombinant DNA technology, selectable markers helps in identifying and eliminating non-transformants and selectively permitting the growth of the transformants.

133. Presence of plants arranged into well defined vertical layers depending on their height can be seen best in :

- (1) Tropical Savannah      (2) Tropical Rain Forest
- (3) Grassland                      (4) Temperate Forest

**Answer (2)**

**Sol.** The tropical rain forest have five vertical strata on the basis of height of plants. *i.e.*, ground vegetation, shrubs, short canopy trees, tall canopy trees and tall emergent trees.

134. The genotypes of a Husband and Wife are I<sup>A</sup>I<sup>B</sup> and I<sup>A</sup>i.

Among the blood types of their children, how many different genotypes and phenotypes are possible?

- (1) 3 genotypes ; 3 phenotypes
- (2) 3 genotypes ; 4 phenotypes
- (3) 4 genotypes ; 3 phenotypes
- (4) 4 genotypes ; 4 phenotypes

**Answer (3)**

**Sol.** Husband  $\times$  Wife  
 $I^A I^B \times I^A i$

♀	♂	$I^A$	$I^B$
$I^A$		$I^A I^A$	$I^A I^B$
$i$		$I^A i$	$I^B i$

Number of genotypes = 4

Number of phenotypes = 3

$I^A I^A$  and  $I^A i$  = A

$I^A I^B$  = AB

$I^B i$  = B

135. Zygotic meiosis is characteristic of

- (1) *Marchantia*                      (2) *Fucus*  
 (3) *Funaria*                            (4) *Chlamydomonas*

**Answer (4)**

**Sol.** *Chlamydomonas* has haplontic life cycle hence showing zygotic meiosis or initial meiosis.

136. Which of the following is correctly matched for the product produced by them?

- (1) *Acetobacter aceti* : Antibiotics  
 (2) *Methanobacterium* : Lactic acid  
 (3) *Penicillium notatum* : Acetic acid  
 (4) *Saccharomyces cerevisiae* : Ethanol

**Answer (4)**

**Sol.** *Saccharomyces cerevisiae* is commonly called Brewer's yeast. It causes fermentation of carbohydrates producing ethanol.

137. Frog's heart when taken out of the body continues to beat for some time

Select the best option from the following statements

- (a) Frog is a poikilotherm  
 (b) Frog does not have any coronary circulation  
 (c) Heart is "myogenic" in nature  
 (d) Heart is autoexcitable

Options

- (1) Only (c)                              (2) Only (d)  
 (3) (a) & (b)                            (4) (c) & (d)

**Answer (4)**

**Sol.** Frog or the vertebrates have myogenic heart having self contractile system or are autoexcitable; because of this condition, it will keep on working outside the body for some time.

138. Which statement is wrong for Krebs' cycle?

- (1) There are three points in the cycle where  $NAD^+$  is reduced to  $NADH + H^+$   
 (2) There is one point in the cycle where  $FAD^+$  is reduced to  $FADH_2$   
 (3) During conversion of succinyl CoA to succinic acid, a molecule of GTP is synthesised  
 (4) The cycle starts with condensation of acetyl group (acetyl CoA) with pyruvic acid to yield citric acid

**Answer (4)**

**Sol.** Krebs cycle starts with condensation of acetyl CoA (2C) with oxaloacetic acid (4C) to form citric acid (6C).

139. In case of poriferans the spongocoel is lined with flagellated cells called :

- (1) Ostia  
 (2) Oscula  
 (3) Choanocytes  
 (4) Mesenchymal cells

**Answer (3)**

**Sol.** Choanocytes (collar cells) form lining of spongocoel in poriferans (sponges). Flagella in collar cells provide circulation to water in water canal system.

140. Which of the following RNAs should be most abundant in animal cell?

- (1) r-RNA  
 (2) t-RNA  
 (3) m-RNA  
 (4) mi-RNA

**Answer (1)**

**Sol.** rRNA is most abundant in animal cell. It constitutes 80% of total RNA of the cell.

141. Which among these is the correct combination of aquatic mammals?

- (1) Seals, Dolphins, Sharks  
 (2) Dolphins, Seals, Trygon  
 (3) Whales, Dolphins, Seals  
 (4) Trygon, Whales, Seals

**Answer (3)**

**Sol.** Sharks and Trygon (sting ray) are the members of chondrichthyes (cartilaginous fish) while whale, Dolphin and Seals are aquatic mammals belong to class mammalia.

142. With reference to factors affecting the rate of photosynthesis, which of the following statements is **not** correct?

- (1) Light saturation for CO<sub>2</sub> fixation occurs at 10% of full sunlight
- (2) Increasing atmospheric CO<sub>2</sub> concentration upto 0.05% can enhance CO<sub>2</sub> fixation rate
- (3) C<sub>3</sub> plants responds to higher temperatures with enhanced photosynthesis while C<sub>4</sub> plants have much lower temperature optimum
- (4) Tomato is a greenhouse crop which can be grown in CO<sub>2</sub> - enriched atmosphere for higher yield

**Answer (3)**

**Sol.** In C<sub>3</sub> plants photosynthesis is decreased at higher temperature due to increased photorespiration.

C<sub>4</sub> plants have higher temperature optimum because of the presence of pyruvate phosphate dikinase enzyme, which is sensitive to low temperature.

143. Asymptote in a logistic growth curve is obtained when

- (1) The value of 'r' approaches zero
- (2) K = N
- (3) K > N
- (4) K < N

**Answer (2)**

**Sol.** A population growing in a habitat with limited resources shows logistic growth curve.

For logistic growth

$$\frac{dN}{dt} = rN \left( \frac{K - N}{K} \right)$$

$$\text{If } K = N \text{ then } \frac{K - N}{K} = 0$$

$$\therefore \text{ the } \frac{dN}{dt} = 0,$$

the population reaches asymptote.

144. Out of 'X' pairs of ribs in humans only 'Y' pairs are true ribs. Select the option that correctly represents values of X and Y and provides their explanation :

- (1) X = 12, Y = 7      True ribs are attached dorsally to vertebral column and ventrally to the sternum
- (2) X = 12, Y = 5      True ribs are attached dorsally to vertebral column and sternum on the two ends

(3) X = 24, Y = 7

True ribs are dorsally attached to vertebral column but are free on ventral side

(4) X = 24, Y = 12

True ribs are dorsally attached to vertebral column but are free on ventral side

**Answer (1)**

**Sol.** In human, 12 pairs of ribs are present in which 7 pairs of ribs (1<sup>st</sup> to 7<sup>th</sup> pairs) are attached dorsally to vertebral column and ventrally to the sternum.

145. The DNA fragments separated on an agarose gel can be visualised after staining with

- (1) Bromophenol blue
- (2) Acetocarmine
- (3) Aniline blue
- (4) Ethidium bromide

**Answer (4)**

**Sol.** Ethidium bromide is used to stain the DNA fragments and will appear as orange coloured bands under UV light.

146. Functional megaspore in an angiosperm develops into

- (1) Ovule
- (2) Endosperm
- (3) Embryo sac
- (4) Embryo

**Answer (3)**

**Sol.** Megaspore is the first cell of female gametophytic generation in angiosperm. It undergoes three successive generations of free nuclear mitosis to form 8-nucleated and 7-celled embryo sac.

147. Among the following characters, which one was not considered by Mendel in his experiments on pea?

- (1) Stem – Tall or Dwarf
- (2) Trichomes – Glandular or non-glandular
- (3) Seed – Green or Yellow
- (4) Pod – Inflated or Constricted

**Answer (2)**

**Sol.** During his experiments Mendel studied seven characters.

Nature of trichomes *i.e.*, glandular or non-glandular was not considered by Mendel.

148. Lungs are made up of air-filled sacs the alveoli. They do not collapse even after forceful expiration, because of :

- (1) Residual Volume
- (2) Inspiratory Reserve Volume
- (3) Tidal Volume
- (4) Expiratory Reserve Volume

**Answer (1)**

**Sol.** Volume of air present in lungs after forceful expiration as residual volume which prevents the collapsing of alveoli even after forceful expiration.

149. GnRH, a hypothalamic hormone, needed in reproduction, acts on

- (1) Anterior pituitary gland and stimulates secretion of LH and oxytocin
- (2) Anterior pituitary gland and stimulates secretion of LH and FSH
- (3) Posterior pituitary gland and stimulates secretion of oxytocin and FSH
- (4) Posterior pituitary gland and stimulates secretion of LH and relaxin

**Answer (2)**

**Sol.** Hypothalamus secretes GnRH which stimulates anterior pituitary gland for the secretion of gonadotropins (FSH and LH).

150. In *Bougainvillea* thorns are the modifications of

- (1) Stipules
- (2) Adventitious root
- (3) Stem
- (4) Leaf

**Answer (3)**

**Sol.** Thorns are hard, pointed straight structures for protection. These are modified stem

151. Which one from those given below is the period for Mendel's hybridization experiments?

- (1) 1856 - 1863
- (2) 1840 - 1850
- (3) 1857 - 1869
- (4) 1870 - 1877

**Answer (1)**

**Sol.** Mendel conducted hybridization experiments on Pea plant for 7 years between 1856 to 1863 and his data was published in 1865 (according to NCERT).

152. Good vision depends on adequate intake of carotene rich food

Select the best option from the following statements

- (a) Vitamin A derivatives are formed from carotene
- (b) The photopigments are embedded in the membrane discs of the inner segment

(c) Retinal is a derivative of vitamin A

(d) Retinal is a light absorbing part of all the visual photopigments

(1) (a) & (b)

(2) (a), (c) & (d)

(3) (a) & (c)

(d) (b), (c) & (d)

**Answer (2)**

**Sol.** Carotene is the source of retinal which is involved in formation of rhodopsin of rod cells. Retinal, a derivative of vitamin A, is the light-absorbing part of all visual photopigments.

153. Which one of the following statements is not valid for aerosols?

- (1) They are harmful to human health
- (2) They alter rainfall and monsoon patterns
- (3) They cause increased agricultural productivity
- (4) They have negative impact on agricultural land

**Answer (3)**

**Sol.** Aerosols can cause various problems to agriculture through its direct or indirect effects on plants. However continually increasing air pollution may represent a persistent and largely irreversible threat to agriculture in the future.

154. A decrease in blood pressure/volume will not cause the release of

- (1) Renin
- (2) Atrial Natriuretic Factor
- (3) Aldosterone
- (4) ADH

**Answer (2)**

**Sol.** A decrease in blood pressure / volume stimulates the release of renin, aldosterone, and ADH while increase in blood pressure / volume stimulates the release of Atrial Natriuretic Factor (ANF) which cause vasodilation and also inhibits RAAS (Renin Angiotensin Aldosterone System) mechanism that decreases the blood volume/pressure.

155. Homozygous purelines in cattle can be obtained by

- (1) mating of related individuals of same breed
- (2) mating of unrelated individuals of same breed
- (3) mating of individuals of different breed
- (4) mating of individuals of different species

**Answer (1)**

**Sol.** Inbreeding results in increase in the homozygosity. Therefore, mating of the related individuals of same breed will increase homozygosity.

156. The vascular cambium normally gives rise to

- (1) Phelloderm
- (2) Primary phloem
- (3) Secondary xylem
- (4) Periderm

**Answer (3)**

**Sol.** During secondary growth, vascular cambium gives rise to secondary xylem and secondary phloem. Phelloderm is formed by cork cambium.

157. Which of the following statements is correct?

- (1) The ascending limb of loop of Henle is impermeable to water
- (2) The descending limb of loop of Henle is impermeable to water
- (3) The ascending limb of loop of Henle is permeable to water
- (4) The descending limb of loop of Henle is permeable to electrolytes

**Answer (1)**

**Sol.** Descending limb of loop of Henle is permeable to water but impermeable to electrolytes while ascending limb is impermeable to water but permeable to electrolytes.

158. Fruit and leaf drop at early stages can be prevented by the application of

- (1) Cytokinins
- (2) Ethylene
- (3) Auxins
- (4) Gibberellic acid

**Answer (3)**

**Sol.** Auxins prevent premature leaf and fruit fall.

NAA prevents fruit drop in tomato; 2,4-D prevents fruit drop in *Citrus*.

159. A baby boy aged two years is admitted to play school and passes through a dental check-up. The dentist observed that the boy had twenty teeth. Which teeth were absent?

- (1) Incisors
- (2) Canines
- (3) Pre-molars
- (4) Molars

**Answer (3)**

**Sol.** Total number of teeth in human child = 20. Premolars are absent in primary dentition.

160. An important characteristic that Hemichordates share with Chordates is

- (1) Absence of notochord
- (2) Ventral tubular nerve cord
- (3) Pharynx with gill slits
- (4) Pharynx without gill slits

**Answer (3)**

**Sol.** Pharyngeal gill slits are present in hemichordates as well as in chordates. Notochord is present in chordates only. Ventral tubular nerve cord is characteristic feature of non-chordates.

161. Artificial selection to obtain cows yielding higher milk output represents

- (1) Stabilizing selection as it stabilizes this character in the population
- (2) Directional as it pushes the mean of the character in one direction
- (3) Disruptive as it splits the population into two one yielding higher output and the other lower output
- (4) Stabilizing followed by disruptive as it stabilizes the population to produce higher yielding cows

**Answer (2)**

**Sol.** Artificial selection to obtain cow yielding higher milk output will shift the peak to one direction, hence, will be an example of Directional selection. In stabilizing selection, the organisms with the mean value of the trait are selected. In disruptive selection, both extremes get selected.

162. Select the **correct** route for the passage of sperms in male frogs :

- (1) Testes → Bidder's canal → Kidney → Vasa efferentia → Urinogenital duct → Cloaca
- (2) Testes → Vasa efferentia → Kidney → Seminal Vesicle → Urinogenital duct → Cloaca
- (3) Testes → Vasa efferentia → Bidder's canal → Ureter → Cloaca
- (4) Testes → Vasa efferentia → Kidney → Bidder's canal → Urinogenital duct → Cloaca

**Answer (4)**

**Sol.** In male frog the sperms will move from

Testes → Vasa efferentia → Kidney → Bidder's canal → Urinogenital duct → Cloaca.

163. Which of the following options best represents the enzyme composition of pancreatic juice?

- (1) Amylase, peptidase, trypsinogen, rennin
- (2) Amylase, pepsin, trypsinogen, maltase
- (3) Peptidase, amylase, pepsin, rennin
- (4) Lipase, amylase, trypsinogen, procarboxypeptidase

**Answer (4)**



**Sol.** Rennin and Pepsin enzymes are present in the gastric juice. Maltase is present in the intestinal juice.

164. Phosphoenol pyruvate (PEP) is the primary  $\text{CO}_2$  acceptor in :

- (1)  $\text{C}_3$  plants
- (2)  $\text{C}_4$  plants
- (3)  $\text{C}_2$  plants
- (4)  $\text{C}_3$  and  $\text{C}_4$  plants

**Answer (2)**

**Sol.** PEP is 3C compound which serves as primary  $\text{CO}_2$  acceptor in the mesophyll cell cytoplasm of  $\text{C}_4$  plants like maize, sugarcane, *Sorghum* etc.

165. The morphological nature of the edible part of coconut is

- (1) Perisperm
- (2) Cotyledon
- (3) Endosperm
- (4) Pericarp

**Answer (3)**

**Sol.** Coconut has double endosperm with liquid endosperm and cellular endosperm.

166. Anaphase promoting complex (APC) is a protein degradation machinery necessary for proper mitosis of animal cells. If APC is defective in a human cell, which of the following is expected to occur?

- (1) Chromosomes will not condense
- (2) Chromosomes will be fragmented
- (3) Chromosomes will not segregate
- (4) Recombination of chromosome arms will occur

**Answer (3)**

**Sol.** Anaphase Promoting Complex (APC) is a protein necessary for separation of daughter chromosomes during anaphase. If APC is defective then the chromosomes will fail to segregate during anaphase.

167. MALT constitutes about \_\_\_\_\_ percent of the lymphoid tissue in human body.

- (1) 50%
- (2) 20%
- (3) 70%
- (4) 10%

**Answer (1)**

**Sol.** MALT is Mucosa Associated Lymphoid Tissue and it constitutes about 50 percent of the lymphoid tissue in human body.

168. Receptor sites for neurotransmitters are present on

- (1) Membranes of synaptic vesicles
- (2) Pre-synaptic membrane
- (3) Tips of axons
- (4) Post-synaptic membrane

**Answer (4)**

**Sol.** Pre-synaptic membrane is involved in the release of neurotransmitter in the chemical synapse. The receptors sites for neurotransmitters are present on post-synaptic membrane.

169. Hypersecretion of Growth Hormone in adults does not cause further increase in height, because

- (1) Growth Hormone becomes inactive in adults
- (2) Epiphyseal plates close after adolescence
- (3) Bones loose their sensitivity to Growth Hormone in adults
- (4) Muscle fibres do not grow in size after birth

**Answer (2)**

**Sol.** Epiphyseal plate is responsible for the growth of bone which close after adolescence so hypersecretion of growth hormone in adults does not cause further increase in height.

170. Alexander Von Humbolt described for the first time

- (1) Ecological Biodiversity
- (2) Laws of limiting factor
- (3) Species area relationships
- (4) Population Growth equation

**Answer (3)**

**Sol.** Alexander Von Humboldt observed that within a region species richness increases with the increases in area.

171. Myelin sheath is produced by

- (1) Schwann Cells and Oligodendrocytes
- (2) Astrocytes and Schwann Cells
- (3) Oligodendrocytes and Osteoclasts
- (4) Osteoclasts and Astrocytes

**Answer (1)**

**Sol.** Oligodendrocytes are neuroglial cells which produce myelin sheath in central nervous system while Schwann cell produces myelin sheath in peripheral nervous system.

172. In case of a couple where the male is having a very low sperm count, which technique will be suitable for fertilisation?

- (1) Intrauterine transfer
- (2) Gamete intracytoplasmic fallopian transfer
- (3) Artificial Insemination
- (4) Intracytoplasmic sperm injection

**Answer (3)**

**Sol.** Infertility cases due to inability of the male partner to inseminate the female or due to very low sperm count in the ejaculates, could be corrected by artificial insemination (AI).

173. Which of the following components provides sticky character to the bacterial cell?

- (1) Cell wall                      (2) Nuclear membrane  
(3) Plasma membrane      (4) Glycocalyx

**Answer (4)**

**Sol.** Sticky character of the bacterial wall is due to glycocalyx or slime layer. This layer is rich in glycoproteins.

174. DNA replication in bacteria occurs

- (1) During S-phase  
(2) Within nucleolus  
(3) Prior to fission  
(4) Just before transcription

**Answer (3)**

**Sol.** DNA replication in bacteria occurs prior to fission. Prokaryotes do not show well marked S-phase due to their primitive nature.

175. The function of copper ions in copper releasing IUD's is :

- (1) They suppress sperm motility and fertilising capacity of sperms  
(2) They inhibit gametogenesis  
(3) They make uterus unsuitable for implantation  
(4) They inhibit ovulation

**Answer (1)**

**Sol.**  $\text{Cu}^{2+}$  interfere in the sperm movement, hence suppress the sperm motility and fertilising capacity of sperms.

176. Which of the following in sewage treatment removes suspended solids?

- (1) Tertiary treatment      (2) Secondary treatment  
(3) Primary treatment      (4) Sludge treatment

**Answer (3)**

**Sol.** Primary treatment is a physical process which involves sequential filtration and sedimentation.

177. The water potential of pure water is

- (1) Zero  
(2) Less than zero  
(3) More than zero but less than one  
(4) More than one

**Answer (1)**

**Sol.** By convention, the water potential of pure water at standard temperature, which is not under any pressure, is taken to be zero.

178. Identify the wrong statement in context of heartwood.

- (1) Organic compounds are deposited in it  
(2) It is highly durable  
(3) It conducts water and minerals efficiently  
(4) It comprises dead elements with highly lignified walls

**Answer (3)**

**Sol.** Heartwood is physiologically inactive due to deposition of organic compounds and tyloses formation, so this will not conduct water and minerals.

179. Thalassaemia and sickle cell anemia are caused due to a problem in globin molecule synthesis. Select the correct statement.

- (1) Both are due to a qualitative defect in globin chain synthesis  
(2) Both are due to a quantitative defect in globin chain synthesis  
(3) Thalassaemia is due to less synthesis of globin molecules  
(4) Sickle cell anemia is due to a quantitative problem of globin molecules

**Answer (3)**

**Sol.** Thalassaemia differs from sickle-cell anaemia in that the former is a quantitative problem of synthesising too few globin molecules while the latter is a qualitative problem of synthesising an incorrectly functioning globin.

180. Flowers which have single ovule in the ovary and are packed into inflorescence are usually pollinated by

- (1) Water  
(2) Bee  
(3) Wind  
(4) Bat

**Answer (3)**

**Sol.** Wind pollination or anemophily is favoured by flowers having a single ovule in each ovary, and numerous flowers packed in an inflorescence. Wind pollination is a non-directional pollination.